

Investment Cast Ball Valves ANSI 150-600 1/2" - 2"

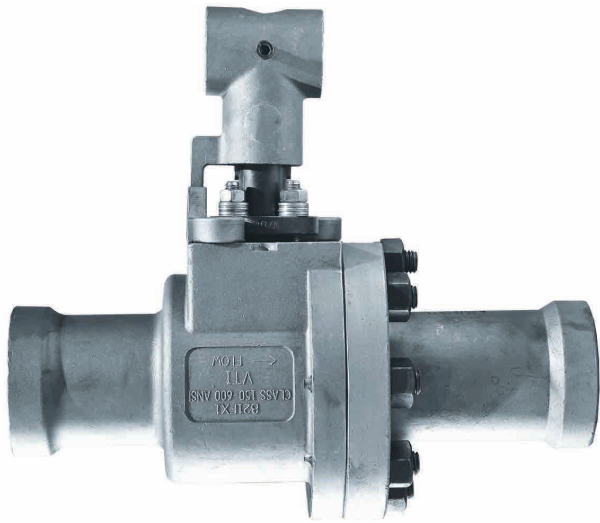

BUTT WELD ENDS

SIZE	A	B	C	D	F	G	J	STEM DIA.	APPROXIMATE WEIGHT (Lb.)	Cv
1/2	6.31	4.59	1.375	3.75	7.12	.63	.84	.50	9	42
3/4	6.31	4.59	1.375	3.75	7.12	.63	1.05	.50	9	30
1	6.31	4.59	1.375	4.20	7.12	.63	1.315	.50	10	20
1	7.75	5.66	1.875	4.06	15	1.06	1.315	.75	21	130
1-1/2	7.75	5.66	1.875	5.38	15	1.06	1.90	.75	24	55
2	13.75	5.66	1.875	5.38	15	1.06	1.90	.75	27	50

SOCKET WELD ENDS

SIZE	A	B	C	D	E	F	G	H	J	STEM DIA.	APPROXIMATE WEIGHT (Lb.)	Cv
1/2	6.31	4.59	1.375	3.75	0.855	7.12	0.63	0.38	1.33	0.5	9	42
3/4	6.31	4.59	1.375	4.89	1.065	7.12	0.63	0.5	1.75	0.5	10	42
1	6.25	4.59	1.375	4.89	1.33	7.12	0.63	0.5	1.75	0.5	10	20
1	7.75	5.66	1.875	4.06	1.33	15	1.06	0.5	1.9	0.75	21	130
1-1/2	7.75	5.66	1.875	5.38	1.93	15	1.06	0.75	2.5	0.75	24	60
1-1/2	9.5	6.31	2.25	4.6	1.93	18*	1.5	0.75	2.92	0.75	30	270
2	8	5.66	1.875	5.79	2.4	15	1.06	0.75	3	0.75	35	50
2	9.5	6.31	2.25	4.6	2.4	18*	1.5	0.75	2.92	0.75	35	135
2	11.5	7.25	2.88	5	2.4	18*	2.13	0.75	3.31	1	80	570

* Symmetric about stem centerline
** Cv is based on actual bore, G

BILLS OF MATERIALS

ITEM	DESCRIPTION	MATERIAL			QTY.
		A105 CARBON STEEL BODY TRIM	316 STAINLESS STEEL BODY TRIM	F22 (2 1/4 Cr-1 Mo.) ALLOY STEEL	
1	BALL	A182-F316/RAM31	A182-F316/RAM31	410S.S./RAM31	1
2	UPSTREAM SEAT	A182-F316/H.F.	A182-F316/H.F.	A182-F316/H.F.	1
3	BELLEVILLE SPRING	INCONEL 718	INCONEL 718	INCONEL 718	1
4	STEM	316 S.S.	316 S.S.	316 S.S.	1
5	GLAND	A182-F22/H.F.	A182-F22/H.F.	A182-F22/H.F.	1
6	GLAND LOAD SPRING	302 S.S.	302 S.S.	302 S.S.	24
7	GLAND NUT	A194 Gr. 8M	A194 Gr. 8M	A194 Gr. 8M	4
8	GLAND STUD	A193 Gr. B8M	A193 Gr. B8M	A193 Gr. B8M	4
9	END CAP/INTEGRAL SEAT	A105/RAM31	A182 -F316/RAM31	A182 -F22/RAM31	1
10	BODY	A216-WCB	A351 GR CF8M	A217-WC9	1
11	BODY GASKET	17-4	17-4	17-4	1
12	GLAND PACKING	316 S.S./GRAFOIL	316 S.S./GRAFOIL	316 S.S./GRAFOIL	1
13	KEY	STEEL	STEEL	STEEL	2
15	DRIVE SLEEVE	4130	4130	4130	1
16	HANDLE	STEEL	STEEL	STEEL	1
17	BODY STUD	A193 Gr. B8M	A193 Gr. B8M	A193 Gr. B8M	4**
18	BODY NUT	A194 Gr. 8M	A194 Gr. 8M	A194 Gr. 8M	4**

** Quantity is 6 for 1-1/8" Ball
Consult factory for other material options. Also available with NPT ENDS - consult factory.

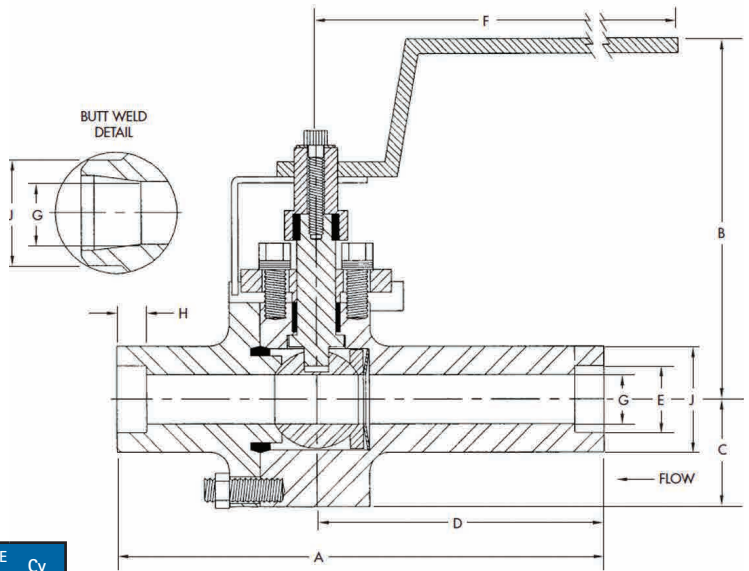

Note: Drawing represents 1/2" and 3/4" valves only.

AVAILABLE BODY OPTIONS:

- Titanium
- Inconel
- Monel
- Nickel
- Duplex Stainless Steel
- 347 Stainless Steel
- 5 Chrome
- 9 Chrome
- WCB
- Hastelloy

V1-3 PRESSURE – TEMPERATURE RATINGS

ANSI 150

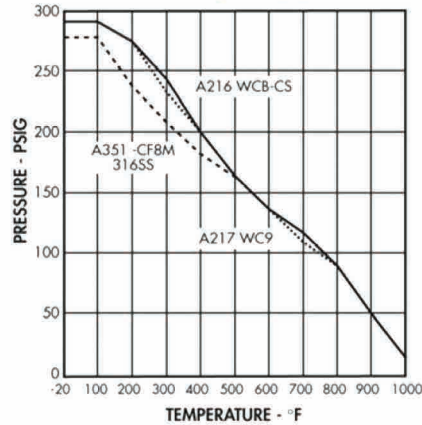

ANSI 300

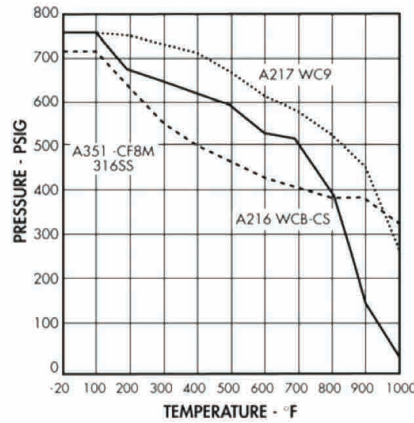

ANSI 600

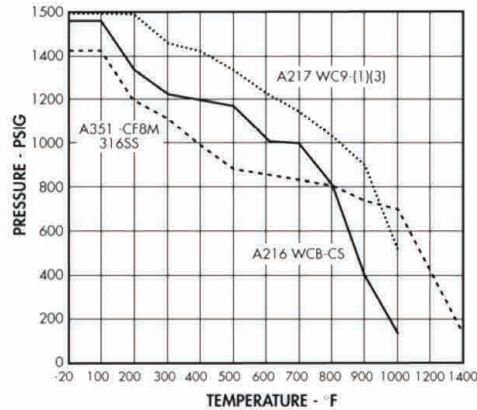

Pressure-temperature ratings are in accordance with ASME/ANSI B16.34 - 2013

Corporate Offices and Manufacturing

Headquarters
ValvTechnologies, Inc.
5904 Bingle Road
Houston, Texas 77092 U.S.A.
Telephone +1 713 860 0400
Fax +1 713 860 0499
sales@valv.com

Master distributors in:

- The Americas
- Europe
- Africa
- Middle East
- India
- Australasia
- China

To locate a master distributor
or satellite office near you,
visit us online at:
www.valv.com