

Valves for the Power Industry

Critical Service Solutions

Severe Service • Zero-Leakage • Metal-Seated



While many manufacturers have tried to achieve a bubble tight seal, ValvTechnologies has lead the way by offering an absolute ZERO-LEAKAGE design that increases plant heat-rate efficiencies and reduces emissions, maintenance and costly down-time.

Critical Service Valve Applications

ValvTechnologies' valves are built to withstand the most severe applications. High-temperature, high-pressure, high-cycling, abrasive, corrosive and caustic media have all been considered in the design of our product line.

ValvTechnologies provides field proven solutions for severe service applications.

LP Feedwater System

- Feed water inlet isolation
- Feed water outlet isolation
- Bypass isolation
- Shell side vents
- Shell side drains
- Level control isolation
- Manual dump to condenser
- Shell side instrument isolation
- Instrument Isolation

Sootblower System

- Sootblower header isolation
- Sootblower control valve isolation
- Sootblower control valve downstream block
- Sootblower header crossover isolation
- Individual sootblower isolation
- Sootblower drains
- Instrumentation

HP Feedwater System

- BFP recirc isolation
- BFP discharge isolation
- BFP turbine above & below seat drains
- Feedwater heater isolation inlet & outlet
- Feedwater heater bypass
- Shell side water level control isolation / heater drain
- Feed water drains
- Shell side drains & vents
- Instrument isolation
- BFP recirc

Hot & Cold Reheat Steam Lines

- Drains & vents

Turbine Steam & Extraction System

- Main steam drains
- Main steam stop before & after seat drains
- Main steam turbine isolation, double block and bleed
- Main steam attemperator / superheat / reheat spray isolation
- HP turbine bypass
- Turbine drains
- Extraction steam isolation
- Extraction steam drain valves

In critical service applications, valve leakage means risk to personal safety, the environment and plant efficiency.

Boiler System

- Economizer drains & vents
- Water wall header drains & vents
- Mud drum blowdown
- Steam drum gauge / sight glass isolation
- Start-up, drum level control
- Steam drum continuous blowdown & block
- Steam drum instrument isolation
- Secondary superheater header drains & vents
- Secondary superheater instrument isolation
- Primary superheater header drains & vents
- Primary superheater instrument isolation
- Reheat superheat header drains & vents
- Reheat superheat instrument isolation
- Reheat spray isolation
- Electronic relief valve & isolation

Combined Cycle / Co-Generation

- BFP recirc
- BFP recirc isolation
- HP economizer drains / vents
- IP economizer drains / vents
- LP steam drum drains / vents
- HP / IP drum pressure & level transmitter instrumentation
- Saturated steam isolation
- Steam drum gauge / sight glass isolation
- Superheater drains / vents
- Hot reheater & main steam isolation drains & vents
- Electronic relief valve
- Main steam start-up vent
- Main steam attemperator / superheat spray isolation
- Turbine bypass system
- Fuel gas heat exchanger
- Instrument isolation
- Emergency gas valve isolation

V1 Series

The Flagship of the ValvTechnologies Product Line.

The critical service needs drive the design features of ValvTechnologies' valves.

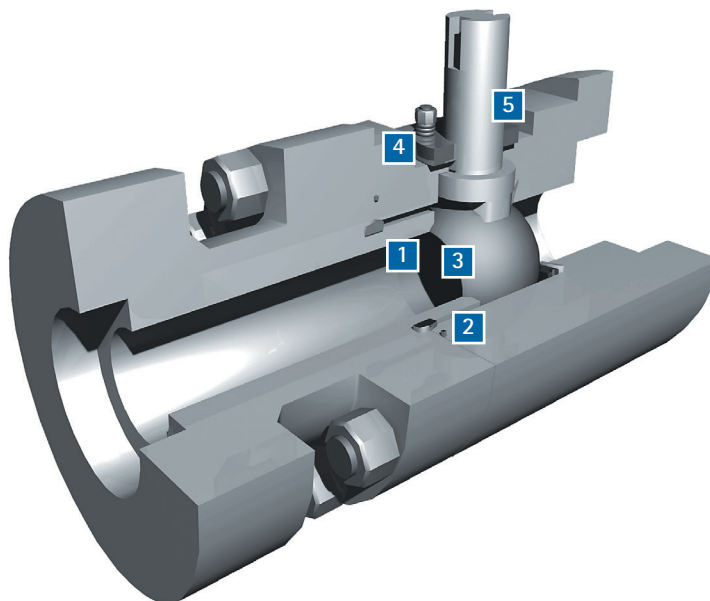

1 Integral Metal Seat.

With our patented HVOF ceramet coating technology, the integral seat in ValvTechnologies' valves is resistant to the attack of abrasive magnetite and ferrous oxides that may be seen in the steam flow.

2 Body Seal Ring.

ValvTechnologies employs a field proven seal ring technology to ensure sealing under all operating conditions, up to 1400° F. The body seal ring is loaded at a pressure higher than 20,000 PSI. In addition, valves in size 3" and above contain a secondary Grafoil® seal to further ensure reliability.

3 Patented Coating Process.

The sealing surfaces are overlaid with tungsten or chromium carbide using our HVOF ceramet coating process. These surfaces provide a zero-leakage seal and uninterrupted operation in the most severe conditions.

4 Live Loaded Gland Area.

The V1 Series gland packing design features a four stud, live-loaded assembly designed for heavy industrial applications. The packing material is high purity Grafoil® surrounded by carbon fiber / Inconel anti-extrusion rings. The six bellville springs (per stud) provide constant load pressure through extreme thermal shocks and prevent prevent packing failure leaks in high cycle service.

5 Blow-out Proof Stem.

ValvTechnologies' design utilizes a one piece, hard-faced, blow-out proof stem that is inserted through the inside of the body cavity eliminating the possibility of blow-out through the gland area. There are no pins, collars or other devices used to retain the stem in the valve body.

V1 Series Key Performance Features and Benefits

Features	Benefits
Guaranteed tight shut-off	Enhanced process safety
Quarter turn operation - readily automated	Increased safety, ease of operation, reduced space requirements
Low pressure drop - high Cv	Process efficiency
Custom engineered	Process optimization
Dimensions to ANSI B16.10	Interchangeable with equivalent valves
Low emission packing and seals	Reduced emissions
Single piece anti-blow-out stem design	Enhanced personnel safety
Resistant to solids	Reduced maintenance costs, minimum downtime
Certified to use in SIL-3 and SIL-4 loops	Enhanced process safety
Live-loaded gland system (four stud design)	Reduced emissions
Stem fugitive emissions per ISO 15848-1 Class B	Reduced emissions, enhanced process safety
Fire safe certification: API-607	Enhanced process safety
Protected seat design	Reduced maintenance costs, minimum downtime

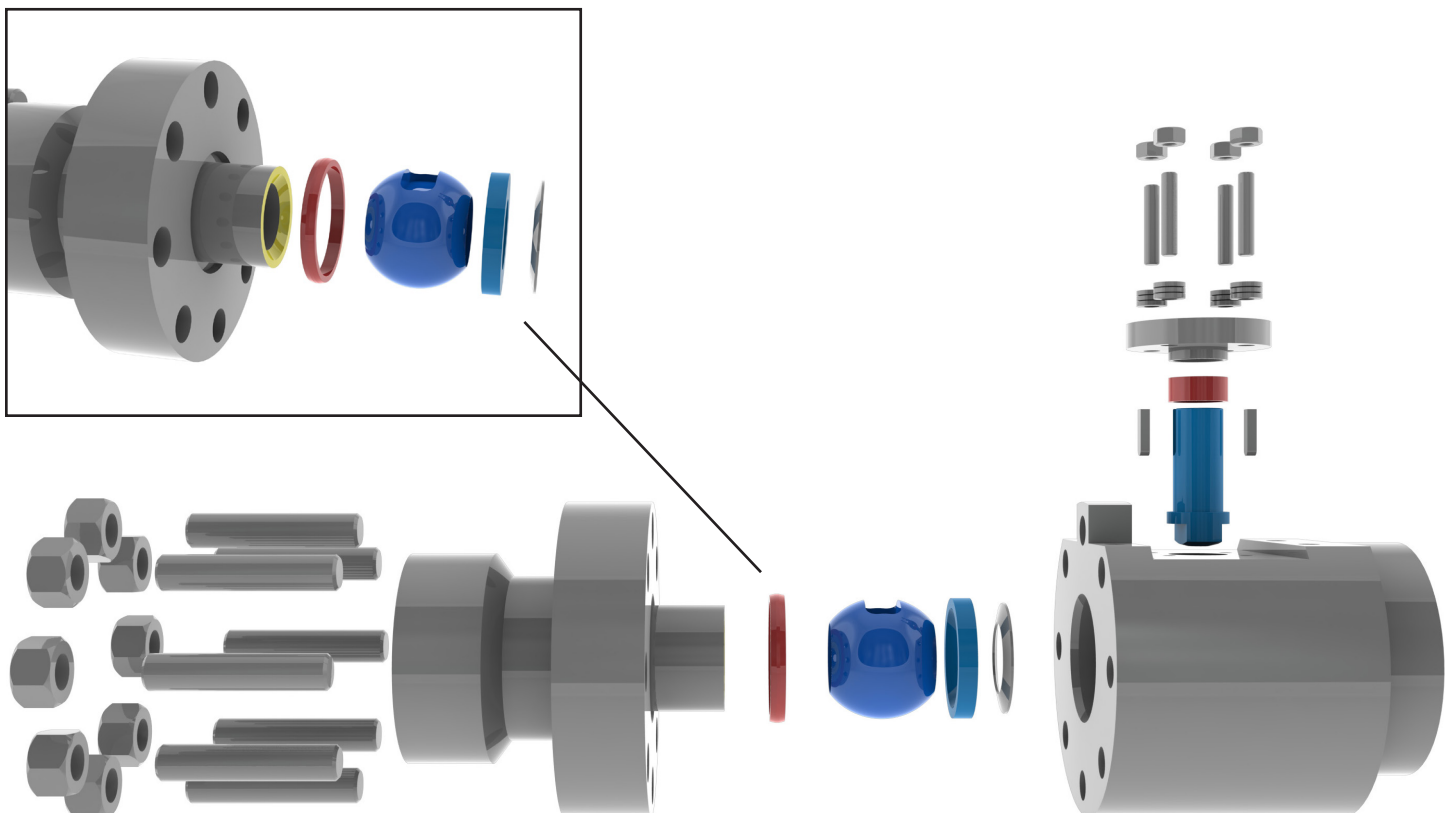

V1 Series

Seat Supported Ball Valves.

The ValvTechnologies' design features are the implementation of extensive industry experience.



V1-1 – 3/8" Bore

Forged, High-Pressure Valves.

- ANSI / ASME Class 900 - 4500
- 3/8"

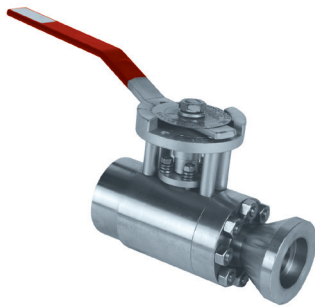

V1-1

Forged, High-Pressure Valves.

- ANSI / ASME Class 900 - 4500
- 1/4 - 4"

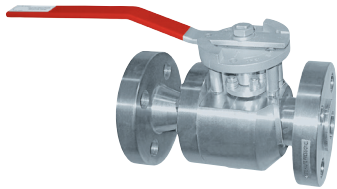

V1-2

Flanged, Low-Pressure Valves.

- ANSI / ASME Class 150 - 600
- 1/2 - 36"

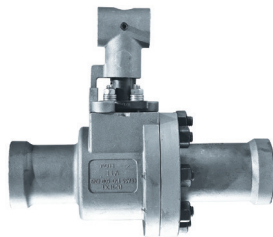

V1-3

Small Bore, Low-Pressure, Investment Cast Valves.

- ANSI / ASME Class 150 - 600
- 1/2 - 2"



V1-4

Large Bore, High-Pressure Valves.

- ANSI / ASME Class 900 - 4500
- 4 - 36"

VALVXPRESS™

ValvXpress™ pre-engineered, automated packages are compact, robust and ready to ship.

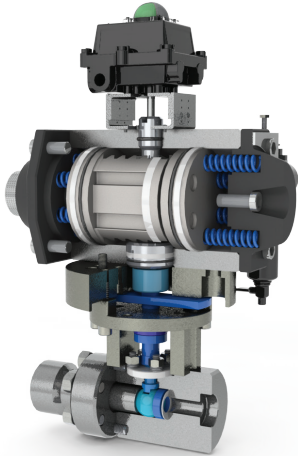

ValvXpress™ is perfect for customers who demand quick delivery of a zero-leakage automated valve solution for severe service water and steam applications. The package includes the superior quality of the V1-1 valve and ValvTechnologies' actuator, backed with the best four-year guarantee in the industry.

The V1-1 proven seat design provides improved performance, far beyond the wear-prone, corrosion-prone crevices of conventional seats. Engineered to eliminate leak paths and maximize direct flow, these units' enhanced rotary design and construction also deliver the extra safety margin crucial to maintaining peak productivity.

ValvXpress™ Actuator

The actuators utilize a rack and pinion design which provides constant torque output in a compact package. The torque output is proportional to the air supply pressure. Twin horizontally opposed cylinders incorporate piston guides to ensure engagement between the rack and pinion. Double acting and spring return models are of comparable compact design.

- Hard anodized body with high-temperature seals
- Maximum working pressure 142 PSI / 10 bar
- Maximum working temperature 320°F / 160°C

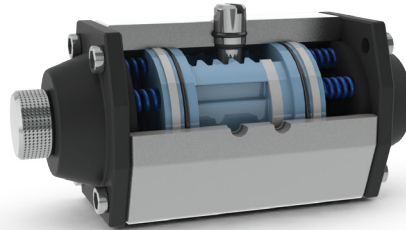

Pre-engineered package includes:

- 1/2 thru 4" metal-seated V1-1 ball valve
- Socket weld and butt weld end connections
- A105, F22, F91 body materials
- 2500#-4500# pressure classes
- Valve operating conditions to 1400°F (760°C)
- High-cycle pneumatic rack and pinion actuator
 - Hard anodized coating
 - High-temperature Viton® seals
- High-cycle mounting hardware
- Limit switch with position indicator – 2-SPDT, quick set cam, IP67, NEMA 4/4X
- NAMUR solenoid – 110V / 120V, 230V, 24VDC coils
- Filter / regulator with gauge
- Unique stem mounting bracket prevents ball from losing position

Parallel Slide Gate (PSG)

True In-Line Repairability.



Pressure Class	ASME / ANSI Class 300 - 4500
Sizes	6 - 36"
Materials of Construction	Carbon steel, alloy steel, stainless steel, duplex steel, exotic alloys
In Compliance	ASME B16.34, PED, N & NPT - Nuclear Authorized
Standard End Connections	BW
Options	Various bypass configurations, actuator mounting

Receive in-line valve repairability in large-diameter, high-energy piping systems with the ValvTechnologies' PSG series. Proven precisely right for steam and feedwater applications, the PSG series offers our rigorous four-year guarantee against leakage and low-cost maintainability.

Bonnet Area

- Sufficient mechanical bolting to ensure the seal does not relax during periods when the system is not pressurized
- High seal reliability
- The bonnet does not have to be forced into the valve bonnet throat to allow for the segment rings to be removed

Gland Area Packing

- The stem and gland are hard faced and polished
- The packing has 316SS woven wire mesh anti-extrusion rings top and bottom and Grafoil center ring
- Proven, superior, multiple Belleville spring stacks
- Live loaded stuffing box

Disc and Seat Area

- Discs and seats have been overlaid with the same carbide overlay (68-72 RC) as its counterpart, the ValvTechnologies' metal-seated ball valve
- Seats are several magnitudes harder than Stellite VI, typically (34-38 RC)
- Lapped to achieve a bubble-tight seal under all pressure conditions, including vacuum
- The large spring load ensures a high initial seal, and the line pressure increases the sealing

Back Seat Area

- The back seat is coated with chrome carbide (typical hardness 68-72 RC) and polished to achieve a bubble-tight seal

Electronic Relief Valve (ERV)

Electronic Operated Relief System.

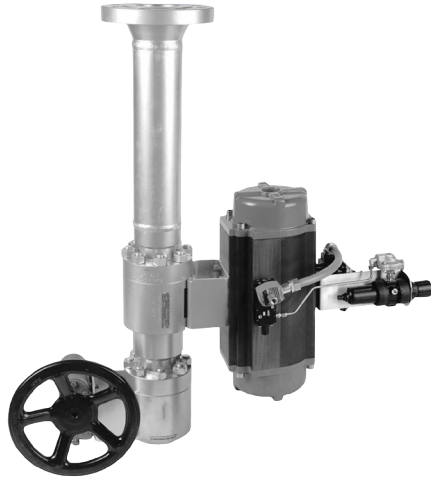

Pressure Class	ASME / ANSI Class 150 - 4500
Sizes	1/2 - 12"
Materials of Construction	Carbon steel, alloy steel, stainless steel, duplex steel, exotic alloys
In Compliance	ASME B16.34, PED, N & NPT - Nuclear Authorized
Standard End Connections	BW, RF
Options	Various control packages available, integral isolation

The ERV package combines ValvTechnologies' zero-leakage isolation valve with electronic controls to monitor and regulate system pressure. Whether in a capacity relieving function requiring the ASME V-stamp or simply in an over pressure protection application, the ERV provides reliable protection for standard safety valves in many industries.

Features

- Repeatable tight shut-off, high precision reliability,
- Zero-leakage guarantee comes standard
- The optional integrated isolation valve eliminates the need for a costly field weld
- Specially engineered for easy adaptation to existing control suites

Standard ERV Package Valve

- Designed to exhaust to atmosphere or into a closed system (superheater bypass)
- Flexibility with both manual and automatic pressure relief of a pressurized system
- Available with complete controls or can utilize existing controls

Actuator Options

- Pneumatic actuation is customary to the ERV
- Multiple actuator relief options – air, spring, hydraulic, AC/DC electric, failsafe and failsafe last position – extend applicability throughout plant or site

ERV Control Box

ValvTechnologies' new light-weight compact control box operates in much the same way as the old but integrates many improvements including better environmental performance, simplified wiring and control, set point programmability and fault indication.

- Enclosure: NEMA 4X, stainless steel
- Auto/Manual Function: Automatic + DCS Auto
- DCS Function: Dry contact
- Fault indication: Yellow LED
- Pressure transmitter: 4-20mA
- Calibrated by PLC interface

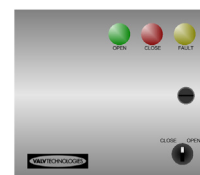

XACTROL®

Tight Shut-Off, High-Pressure Let Down.



Pressure Class	ASME / ANSI Class 900 - 4500
Sizes	1/2 - 36"
Materials of Construction	Carbon steel, alloy steel, stainless steel, duplex steel, exotic alloys
In Compliance	ASME B16.34, PED, N Et NPT - Nuclear Authorized
Standard End Connections	SW, BW, RF
Options	Single stage pressure drop, continuous blowdown, multi-stage pressure drop, actuator mounting

From simple, minimum or normal flow control to a full rangeability over a wide range of pressure drops and conditions, we have the solution for you. The Xactrol® Mark I is designed for minimum or normal flow control conditions as required in a large number of flow control applications. In addition to normal flow control the Mark II design has a second flow port which is designed to handle continuous flow conditions. For applications where high-pressure drops are required, the Mark III design comes with a series of upstream pressure reducing plates to meet the toughest of applications.

Features

- Tight shut-off, high-pressure letdown combination
- MSS-SP-61 or better
- Reduces velocity
- Liquids – eliminates cavitation and flashing
- Gases – eliminates erosion and vibration/noise
- Smaller envelope than comparable globe valve
- Higher Cv than comparable globe valve

Control Options

- Mark I - High-pressure and/or erosive service
- Mark II - High-pressure and/or erosive service with the addition of a required continuous minimum flow
- Mark III - High ΔP liquid applications where cavitation and flashing are a concern, high ΔP gaseous applications where fluid is flowing at sonic velocity

NEXTECH®

Trunnion Mounted Ball Valve.



Pressure Class	ASME / ANSI Class 300 - 2500
Sizes	2 - 24"
Materials of Construction	Carbon steel, alloy steel, stainless steel, chrome alloys
In Compliance	ASME B16.34, ISO 15848-1 Fugitive Emissions, PED, N & NPT - Nuclear Authorized
Standard End Connections	BW, RF, RTJ
Options	Bleed ports, sealant injection ports, body cavity drain and vent ports

This evolutionary trunnion mounted design incorporates many features of our seat-supported valve technology with the additional benefits of low operating torque and bi-directional sealing. The Nextech® family of products is designed to withstand severe thermal swings, meeting stringent emission requirements while providing long life in abrasive and/or erosive conditions.

Turbine Bypass System

Pressure Relief System, IGCC Ready

Pressure Class	ASME / ANSI Class 150 - 4500
Sizes	4 - 24"
Materials of Construction	Carbon steel, alloy steel, stainless steel, duplex steel, exotic alloys
In Compliance	ASME B16.34, PED, N & NPT - Nuclear Authorized
Standard End Connections	BW, RF
Options	Various control packages available, Integral isolation



Keep gas turbine and heat recovery system generators (HRSG) online in the event of a steam turbine trip with ValvTechnologies' TBS. Purposefully designed for the new generation of combined-cycle power plants, our TBS combines the proven Xactrol® severe service control valve design with a state-of-the-art de-superheating control system.

Valves for the Power Industry



ValvTechnologies, Inc. is a global leader in the design and manufacturing of flow control devices. Founded in 1987 and headquartered in Houston, Texas, ValvTechnologies remains focused on helping customers meet their daily production and process challenges safely and efficiently.

Having built a global reputation for superior quality and dependability across every industry served with products designed to fulfill the requirements of standard applications to the most sophisticated, severe service processes, ValvTechnologies meets the demands for total flow control solutions, whether one valve at a time, or system-wide.

Bringing together the best people and the latest in technological design and manufacturing processes, ValvTechnologies has created an atmosphere where quality and dependability are built into every product, start to finish.

Worldwide Office Locations

Headquarters & Manufacturing

ValvTechnologies, Inc.
5904 Bingle Road
Houston, Texas 77092 U.S.A.
Telephone +1 713 860 0400
Fax +1 713 860 0499
info@valv.com

To locate a distributor or satellite office near you, visit us online at: www.valv.com

To contact sales anywhere in the world, email sales@valv.com

Peru

Lima
peru@valv.com

Brazil

São Paulo
brazil@valv.com

United Kingdom

Stockton-on-Tees
europa@valv.com

Australia

Brisbane
australia@valv.com

China

Shanghai
china@valv.com

China

Chengdu
china@valv.com

China

Beijing
china@valv.com

Eastern Europe

Warsaw
poland@valv.com

Middle East

Dubai
middle.east@valv.com

India

Chennai
india@valv.com

Japan/Korea

Seoul
korea@valv.com

Spain

Madrid
spain@valv.com