

V1-1

VALV TECHNOLOGIES

Forged, High Pressure Valves ANSI 900-4500 1/4" - 4"

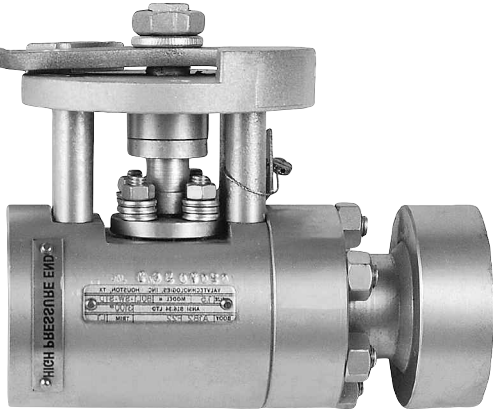

BUTT WELD ENDS

Nom.	A		C		D		E		G	L		Weight(lbs.)	
	2500*	4500**	2500	4500	2500	4500	2500	4500		2500	4500	2500	4500
1/2	5.50	6.75	4.50	4.50	1.94	2.81	1.19	1.31	.84	7.1	7.1	7.4	10
3/4	5.50	6.75	4.50	4.50	1.94	2.81	1.19	1.31	1.05	7.1	7.1	7.4	10
1	8	6.75	5.88	4.50	2.75	2.81	1.75	1.31	1.32	15	7.1	23	10
1-1/4	8	8	5.88	5.88	2.75	2.75	1.75	1.75	1.66	15	15	22	24
1-1/2	8	8	5.88	5.88	8	8	1.75	2.25	1.90	15	15	23	41
2	10	8	6.50	5.88	3.25	3.25	2.13	2.25	2.38	15	15	32	40
2-1/2	10	11.13	6.50	N/A	3.81	3.81	2.13	4.25	2.88	15	N/A	34	53
3	11.50	11.13	N/A	N/A	3.81	3.81	3	3	3.50	N/A	N/A	82	55
4	11.50	11.13	N/A	N/A	3.81	3.81	3	3	4.50	N/A	N/A	85	56

SOCKET WELD ENDS

Nom.	A		B	C		D		E		F	G		L		Weight(lbs.)	
	2500*	4500**		2500	4500	2500	4500	2500	4500		2500	4500	2500	4500	2500	4500
1/4	5.50	-	0.55	4.50	-	1.94	-	1.19	-	0.38	2.14	7.13	7.1	-	7.4	-
3/8	5.50	6.75	0.69	4.50	4.50	1.94	2.81	1.19	1.31	0.38	2.14	1.75	7.1	7.1	7.4	10
1/2	5.50	6.75	0.85	4.50	4.50	1.94	2.81	1.19	1.31	0.50	2.14	2.09	7.1	7.1	7.4	10
3/4	5.50	6.75	1.06	4.50	4.50	1.94	2.81	1.19	1.31	0.50	2.14	2.57	7.1	7.1	7.4	10
1	8	6.75	1.33	5.88	4.50	2.75	2.81	1.75	1.31	.50	2.13	2.57	15	7.1	23	10
1-1/4	8	8	1.67	5.88	5.88	2.75	2.75	1.75	1.75	.50	2.61	3.19	15	15	22	24
1-1/2	8	9.56	1.91	5.88	8	2.75	3.25	1.75	2.25	.50	2.95	4.50	15	15	23	41
2	10	9.56	2.41	6.50	5.88	3.80	3.25	2.13	2.25	.63	3.88	4.50	15	15	35	40

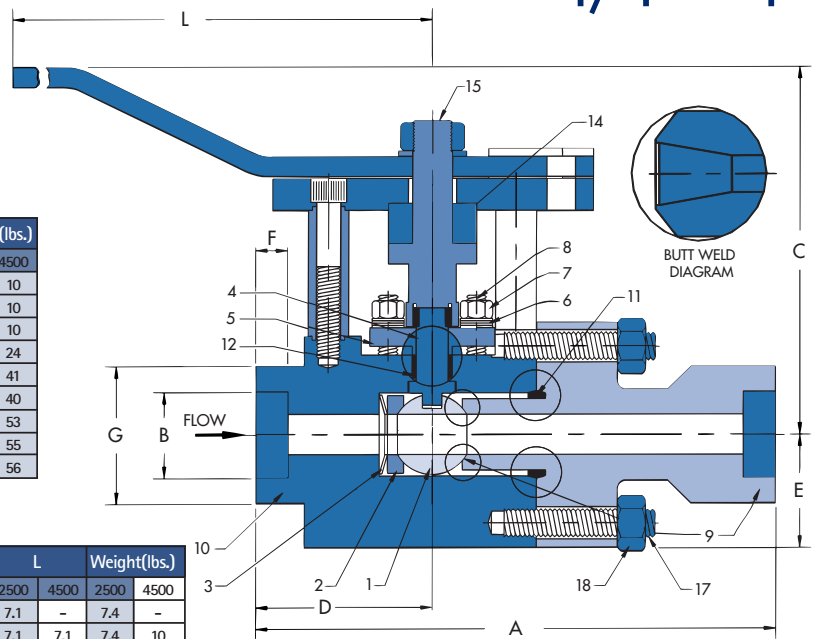

Note: 1. All dimensions are in inches.
2. All dimensional data is approximate, contact factory for certified dimensions.
3. Contact factory for Cv values.
* Dimensions for 2500# class also represent dimensions for 1500# class.
** Dimensions for 4500# class also represent dimensions for 3500# class.

BILLS OF MATERIAL

ITEM	DESCRIPTION	A182-F22	A105	A182-F316	A182-F91	QTY.
1	BALL ***	A182-F6a/RAM31	A182-F6a/RAM31	A182-F6a/RAM31	A638-Gr. 660/RAM31	1*
2	UPSTREAM SEAT	A182-F22 Cl.3/H.F.	A182-F22 Cl.3/H.F.	A182-F316/H.F.	A182-F22 Cl.3/H.F.	1*
3	BELLEVILLE SPRING	UNS N07718	UNS N07718	UNS N07718	UNS N07718	1*
4	STEM	A638-Gr.660/H.F.	A638-Gr.660/H.F.	A638-Gr.660/H.F.	A638-Gr.660/H.F.	1
5	GLAND	A182-F22 Cl.3/H.F.	A182-F22 Cl.3/H.F.	A182-F22 Cl.3/H.F.	A182-F22 Cl.3/H.F.	1
6	GLAND LOAD SPRING	AISI 302	AISI 302	AISI 302	AISI 302	24
7	GLAND NUT	A194 Gr. 8M	A194 Gr. 8M	A194 Gr. 8M	A194 Gr. 8M	4
8	GLAND STUD	A193 Gr. 8B8M	A193 Gr. 8B8M	A193 Gr. 8B8M	A193 Gr. 8B8M	4
9	END CAP/INTEGRAL SEAT	A182-F22 Cl.3/RAM31	A105/RAM31	A182-F316/RAM31	A182-F91/RAM31	1*
10	BODY	A182-F22 Cl.3	A105	A182-F316	A182-F91	1
11	BODY GASKET	A564 TYPE 630 (H1150)	A564 TYPE 630 (H1150)	A564 TYPE 630 (H1150)	A564 TYPE 630 (H1150)	1*
12	GLAND PACKING	AISI 316/GRAFOIL	AISI 316/GRAFOIL	AISI 316/GRAFOIL	AISI 316/GRAFOIL	3*
14	THRUST BEARING	A29-1020/H.F.	A29-1020/H.F.	A29-1020/H.F.	A29-1020/H.F.	1
15	DRIVE SLEEVE	A29-4130	A29-4130	A29-4130	A29-4130	1
17	BODY STUD	A193 Gr. 8B8M	A193 Gr. 8B8M	A193 Gr. 8B8M	A193 Gr. 8B8M	8**
18	BODY NUT	A194 Gr. 8M	A194 Gr. 8M	A194 Gr. 8M	A194 Gr. 8M	8**

* Recommended Spare Parts
** Quantity is 6 for 1/2" through 1 1/2"
***Ball Material is Inconel 7-18 for class 3500# and 4500# valves
A182-F91 trim, the gland material is A182-F316/H.F. for sizes 2" and above

Testing Procedure: As a standard, all valves are seat leak tested with 50-psi of air for 3 minutes with the minimum acceptable passing criteria, being zero bubbles during the 3-minute test. This test exceeds ANSI B16.104/FCI 70-2 Class VI leakage standards. Additionally a 1000-psi nitrogen seat test is performed for 3 minutes with zero bubbles. Furthermore, 3500/4500 ASME/ANSI Class valves are seat leak tested at 4000-psi of nitrogen for 3 minutes with zero bubbles.

V1-1 VALVE Cv's

VALVE NOMINAL SIZE	PIPE I.D.	TRANSITION ANGLE	BORE ²	Cv BASED ON PIPE I.D.	MAXIMUM Cv OF VALVE
1/4"	Sch 80 0.302	0°	0.38	5.2	15
3/8"	Sch 80 0.423	7.5°	0.38	12.9	15
1/2"	Sch 160 0.466	10°	0.38	8.5	15
3/4"	Sch XXS 0.434	10°	0.38	9.9	15
1" 2500#	Sch XXS 0.599	0°	0.63	44	44
1" 4500#	Sch XXS 0.599	10°	0.38	7.5	15
1-1/4"	Sch XXS 0.896	15°	0.63	31	44
1-1/2"	Sch XXS 1.100	15°	0.63	22	44
2" 2500#	Sch XXS 1.503	7.5°	1.06	80	136
2" 4500#	1.900	5°	5/8	19	44
2-1/2"	Sch XXS 1.771	12.5°	1.06	58	136
3" 2500#	Sch XXS 2.300	7°	1.50	162	284
4" 2500#	Sch XXS 3.152	15°	1.50	91	284
3" 4500#	1.900	15°	1.06	60	143
4" 4500#	2.610	15°	1.06	43	143

Since the pipe I.D. and corresponding transition from valve I.D. to pipe I.D. has a critical impact on the Cv of the valve, we have devised the above table. This table gives the Cv based on industry standard pipe and also the maximum Cv of the valve only.

Notes: 1. For Cv with other pipe I.D., consult factory.
2. For Cv with other valve bore, consult factory.
3. Cv values are approximate, contact factory for exact Cv values.

Integral Seat, Four-Year Zero Leakage Guarantee

V1-1 PRESSURE TEMPERATURE RATINGS

A182-F22 (2 1/4 Cr.- 1 Mo.)

MODEL No.*	ANSI Rating	TEMPERATURE, °F																	
		-20 to 100	200	300	400	500	600	650	700	750	800	850	900	950	1000	1050	1100	1150	1200
B7L1	900(1)	2250 psi	2150	2030	1945	1920	1815	1765	1705	1595	1525	1460	1350	1130	780	525	330	205	125
B8L1	1500 2250(2)	5625 psi	5369	5076	4860	4798	4536	4414	4258	3988	3808	3654	3370	2830	1954	1310	824	514	310
B0L1	2500 3100(2)	7750 psi	7551	7226	6956	6721	6249	6081	5866	5492	5244	5034	4644	3901	2692	1806	1134	708	426
BAL1	3500 4000(2)	10000 psi	9929	9604	9289	8806	8063	7845	7569	7085	6765	6494	5991	5035	3475	2333	1463	915	548
BBL1	4500(1)	11250 psi	11250	10925	10585	9965	9070	8825	8515	7970	7610	7305	6740	5665	3910	2625	1645	1030	615

A105 (Carbon Steel)**

MODEL No.*	ANSI Rating	TEMPERATURE, °F													
		-20 to 100	200	300	400	500	600	650	700	750	800	850	900	950	1000
B7C1	900(1)	2250 psi	2025	1970	1900	1795	1640	1610	1600	1510	1235	805	515	310	155
B8C1	1500 2250(2)	5625 psi	5063	4923	4753	4491	4104	4028	3996	3780	3088	2008	1288	774	388
B0C1	2500 3100(2)	7750 psi	6974	6783	6548	6187	5655	5549	5505	5208	4252	2764	1772	1066	532
BAC1	3500 4000(2)	10000 psi	8996	8751	8449	7983	7298	7160	7103	6720	5485	3565	2285	1374	685
BBC1	4500(1)	11250 psi	10120	9845	9505	8980	8210	8055	7990	7560	6170	4010	2570	1545	770

** per ASME/ANSI B16.34
Permissible, but not recommended for prolonged usage above 800 °F.

A182-F316 (316 Stainless Steel)

MODEL No.*	ANSI Rating	TEMPERATURE, °F																	
		650	700	750	800	850	900	950	1000	1050	1100	1150	1200	1250	1300	1350	1400	1450	1500
B721	900(1)	1330 psi	1305	1280	1265	1255	1245	1160	1050	1030	915	710	555	440	350	290	225	175	125
B821	1500 2250(2)	3330 psi	3258	3204	3168	3133	3114	2898	2624	2579	2290	1774	1390	1106	874	720	568	436	310
B021	2500 3100(2)	4588 psi	4489	4415	4365	4316	4291	3993	3614	3552	3154	2444	1914	1524	1204	992	780	602	428
BA21	3500 4000(2)	5920 psi	5791	5698	5631	5569	5538	5151	4663	4583	4068	3155	2468	1965	1555	1280	1005	778	551
BB21	4500(1)	6660 psi	6515	6410	6335	6265	6230	5795	5245	5155	4575	3550	2775	2210	1750	1440	1130	875	620

A182-F91 (9Cr-1 Mo.)

MODEL No.*	ANSI Rating	TEMPERATURE, °F																	
		-20 to 100	200	300	400	500	600	650	700	750	800	850	900	950	1000	1050	1100	1150	1200
B791	900(1)	2250 psi	2250	2185	2115	1995	1815	1765	1705	1595	1525	1460	1350	1109	1090	1080	965	718	448
B891	1500 2250(2)	5625 psi	5625	5463	5293	4986	4536	4414	4258	3988	3808	2904	3370	2898	2728	2700	2416	1800	1105
B091	2500 3100(2)	7750 psi	7750	7527	7292	6868	6249	6081	5866	5492	5244	4334	4644	3993	3756	3720	3330	2480	1523
BA91	3500 4000(2)	10000 psi	10000	9711	9409	8859	8063	7845	7569	7085	6765	6244	5991	5151	4845	4800	4298	3200	1965
BB91	4500(1)	11250 psi	11250	10925	10585	9965	9070	8825	8515	7970	7610	7305	6740	5795	5450	5400	4835	3600	2211

(1) Standard Rating
(2) Interpolated Rating
NOTE: Working Pressures are in accordance with ASME/ANSI B16.34-1996; Standard Class Interpolated Ratings.
F-22 Limited Class 2250, 3100 & 4000 are available upon request.
* Add SW or BW to complete Model Number.

