



## Parallel Slide Gate Valves ANSI 600-4500 6" - 36"

The Valvtechnologies' Parallel Slide Gate Valve (PSG) addresses the need for true in-line valve reparability in large diameter, high-energy piping systems. Specifically designed for steam and feedwater applications, the PSG provides bi-directional, zero leakage using the RAM® coating systems. It is available in sizes 6" to 36", pressure classes ANSI 600 to 4500, and can be manufactured in any material. When used in Power Industry applications, the PSG carries the Valvtechnologies Four-Year, Zero Leakage Guarantee.

### HIGHLIGHTS

- Chrome Carbide Overlay of Stem, Discs, & Guides
- Position Seating
- Internal Travel Position Stops
- External Position Indicator
- Bubble Tight Shut Off
- Live Loaded Stuffing Box
- Reliable Repeatable Shut Off
- Protected Seats

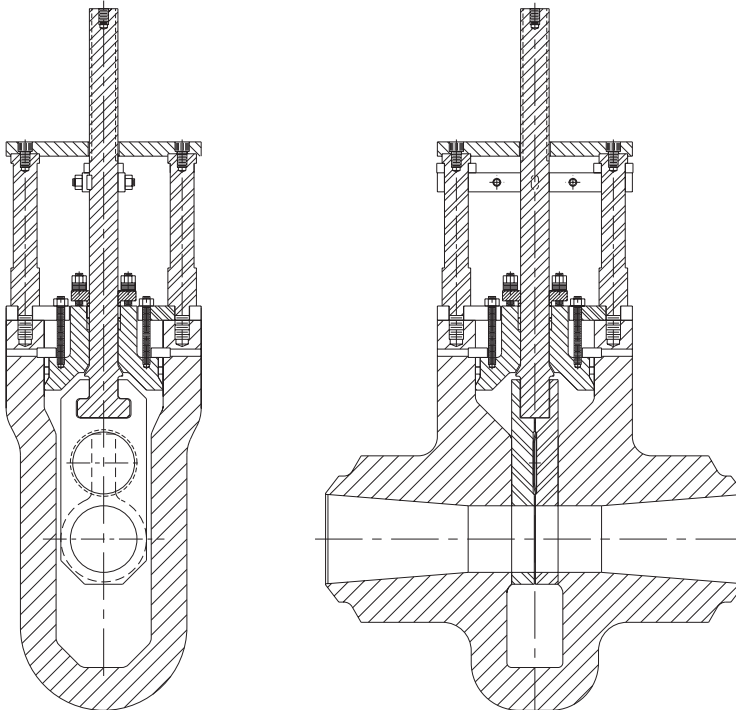

Integral Seat, Four-Year Zero Leakage Guarantee

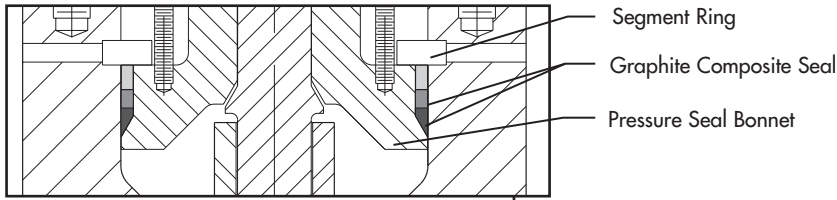

### BONNET AREA

The pressure seal bonnet has been designed with a graphite composite seal. The bonnet has sufficient mechanical bolting to ensure the seal does not relax during periods when the system is not pressurized. In addition to the high reliability of the seal, the bonnet area has been designed to minimize the problems associated with maintenance on large gate valves. The valve has been designed so that the bonnet does not have to be forced in to the valve bonnet throat to allow for the segment rings to be removed. The large bolting used to ensure that the pressure seal is always loaded has also been utilized to enable simple disassembly of the bonnet once the easy to extract segment rings have been removed.

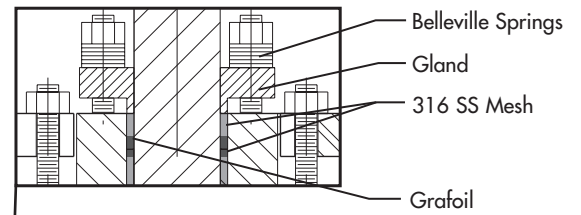

### GLAND AREA

The gland design is similar to the standard design employed throughout the Valvtechnologies' various valve product line, but features additional rings of graphite with a sliding stem. The stem and gland are hard-faced and polished. The packing has a 316SS woven wire mesh anti-extrusion ring on top and bottom and a grafoil center ring. This design is combined with our proven, multiple Belleville spring stacks and live-loaded stuffing box.

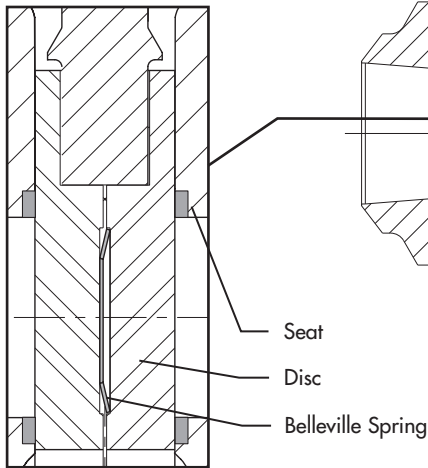

### DISCS & SEAT AREA

The valve discs and seats have been overlaid with the same carbide overlay (68-70 RC) as its counterpart, the Valvtechnologies metal seated ball valve. These seats are several magnitudes harder than Stellite 6, (typically 34-38 RC), and are lapped to achieve a bubble-tight seal under all pressure conditions, including vacuum. The large spring load ensures a high initial seal, and the line pressure increases the sealing. The web guide (which is also carbide overlaid) ensures the discs are kept parallel, whether the valve is in the open or closed position. This overcomes a common gate valve problem. As the valve is cycled under differential pressure, the extremely hard surfaces continually hone and polish each other instead of scratching and galling. The seal is improved rather than degraded with "wear" (use).

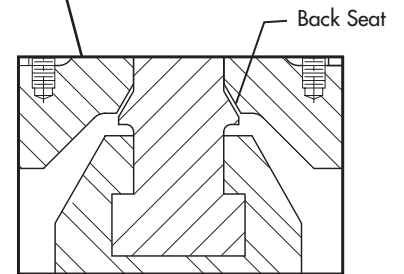
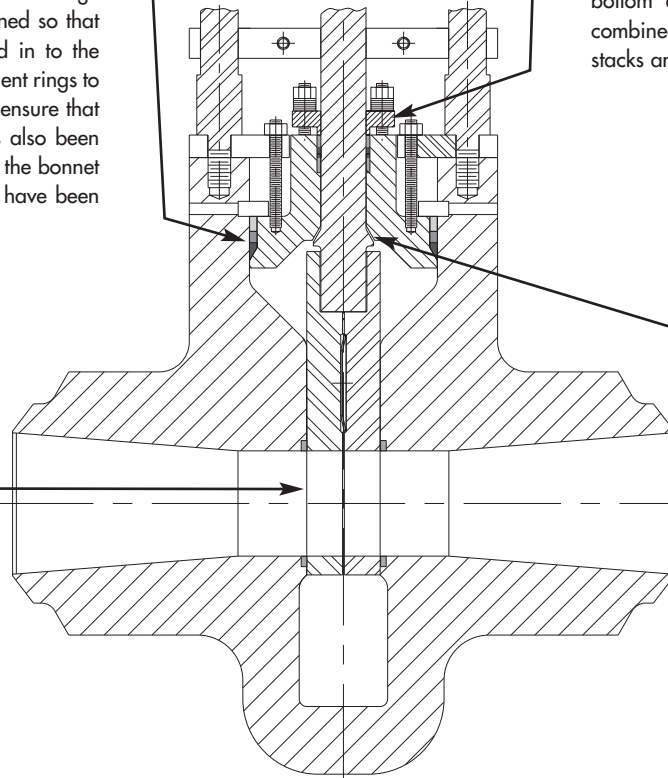

(View is rotated 90° and shown in the open position)

### BACK SEAT AREA

The back seat is coated with chrome carbide (typical hardness 68-70 RC) and polished to achieve a bubble tight seal.

Consult Factory on all weights

600#

On Application

900#

SIZE	A	B	C	D	E	F	Weight(lbs.)	C <sub>v</sub>
6"	3 1/2	6.63	13.00	27.88	24.0	2	850	800
8"	3 1/2	8.63	13.00	27.88	30.0	2	940	500
8"	5 1/8	8.63	16.88	40.75	30.0	2 1/2	1,780	2,500
10"	5 1/8	10.75	16.88	40.75	36.0	2 1/2	1,930	1,500
10"	8	10.75	20.88	53.38	36.0	3 1/2	4,170	7,600
12"	8	12.75	20.88	52.38	41.0	3 1/2	4,350	6,700
14"	8	14.00	20.88	52.38	44.0	3 1/2	4,540	4,400
16"	10	16.00	22.00	65.50	49.0	5	6,650	10,700
18"	10	18.00	22.00	65.50	55.0	5	7,150	6,600
20"	11 3/4	20.00	24.75	76.50	58.0	6	11,600	10,100
24"	13 1/4	24.00	28.00	86.75	60.0	7	15,700	11,900

1500#

SIZE	A	B	C	D	E	F	Weight(lbs.)	C <sub>v</sub>
6"	3 1/2	6.63	9.00	27.88	22.0	1 1/2	580	700
8"	3 1/2	8.63	9.00	27.88	28.0	1 1/2	640	500
8"	5 1/8	8.63	10.75	40.75	28.0	2	1,210	1,700
10"	5 1/8	10.75	10.75	40.75	34.0	2	1,310	1,200
10"	8	10.75	16.88	53.38	34.0	2 1/2	2,830	7,500
12"	8	12.75	16.88	52.38	39.0	2 1/2	2,950	4,400
14"	8	14.00	17.13	52.38	42.0	2 1/2	3,080	3,900
16"	11 3/4	16.00	24.44	76.50	47.0	3 1/2	4,510	16,700
18"	11 3/4	18.00	24.44	76.50	53.0	3 1/2	4,850	10,100
20"	13 1/4	20.00	26.50	86.75	58.0	5	7,890	13,100
24"	15	24.00	30.25	98.19	60.0	5	10,640	15,700

2500#

SIZE	A	B	C	D	E	F	Weight(lbs.)	C <sub>v</sub>
6"	3 1/2	6.63	9.00	27.88	24.0	1 1/2	610	700
8"	3 1/2	8.63	9.00	27.88	30.0	1 1/2	670	500
8"	5 1/8	8.63	10.75	40.75	30.0	2	1,270	1,800
10"	5 1/8	10.75	10.75	40.75	36.0	2	1,380	1,400
10"	8	10.75	16.88	53.38	36.0	2 1/2	2,980	7,500
12"	8	12.75	16.88	52.38	41.0	2 1/2	3,100	4,700
14"	8	14.00	17.13	52.38	44.0	2 1/2	3,240	4,100
16"	11 3/4	16.00	24.44	76.50	49.0	3 1/2	4,750	17,100
18"	11 3/4	18.00	24.44	76.50	55.0	3 1/2	5,100	14,900
20"	13 1/4	20.00	26.50	86.75	58.0	5	8,300	19,700
24"	15	24.00	30.25	98.19	60.0	5	11,200	17,000

4500#

SIZE	A	B	C	D	E	F	Weight(lbs.)	C <sub>v</sub>
6"	3 1/2	6.63	13.00	27.88	24.0	2	850	800
8"	3 1/2	8.63	13.00	27.88	30.0	2	940	500
8"	5 1/8	8.63	16.88	40.75	30.0	2 1/2	1,780	2,500
10"	5 1/8	10.75	16.88	40.75	36.0	2 1/2	1,930	1,500
10"	8	10.75	20.88	53.38	36.0	3 1/2	4,170	7,600
12"	8	12.75	20.88	52.38	41.0	3 1/2	4,350	6,700
14"	8	14.00	20.88	52.38	44.0	3 1/2	4,540	4,400
16"	10	16.00	22.00	65.50	49.0	5	6,650	10,700
18"	10	18.00	22.00	65.50	55.0	5	7,150	6,600
20"	11 3/4	20.00	24.75	76.50	58.0	6	11,600	10,100
24"	13 1/4	24.00	28.00	86.75	60.0	7	15,700	11,900

Note: 1. All dimensions are in inches.  
2. All dimensional data is approximate, contact factory for certified dimensions.  
3. Contact factory for Cv values for additional size requirements.

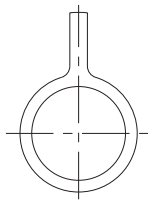

VIEW OF SEAT IN Y-Y DIRECTION

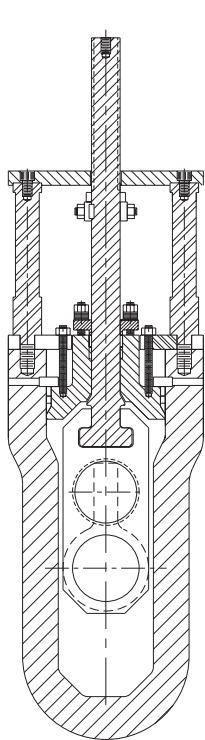
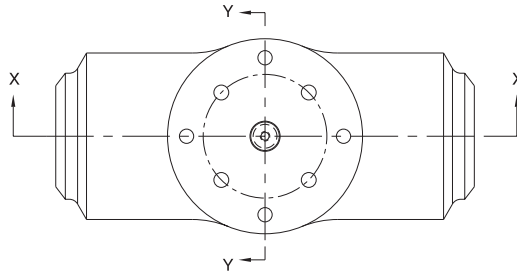

SECTION Y-Y

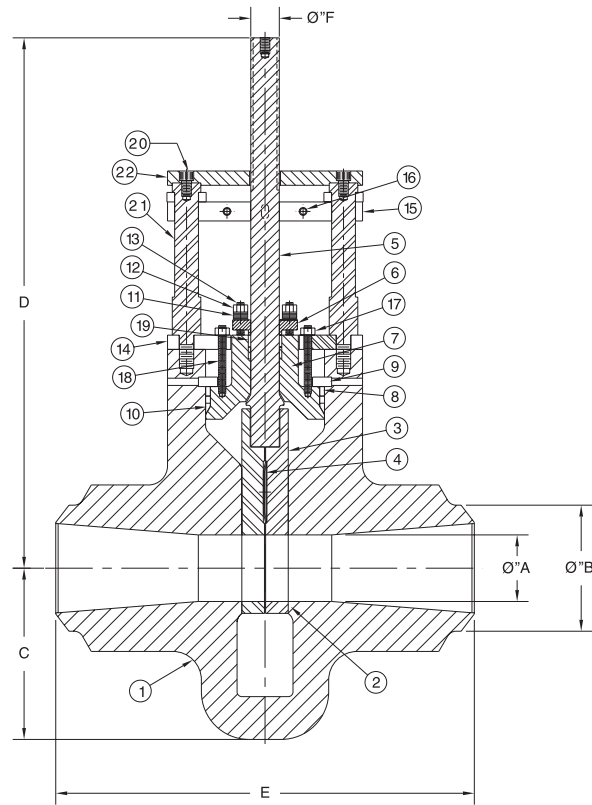

SECTION X-X

### BILLS OF MATERIAL

ITEM	DESCRIPTION
1	BODY
2	SEAT
3	DISC
4	SPRING
5	STEM
6	GLAND
7	BONNET
8	SPACER RING
9	SEGMENT RING
10	PRESSURE SEAL
11	GLAND SPRING
12	GLAND NUT
13	GLAND STUD

ITEM	DESCRIPTION
14	PLATE
15	PLATE NUT
16	PLATE STUD
17	PULLING NUT
18	PULLING STUD
19	BRIDGE
20	BRIDGE BOLTING
21	YOKE POST
22	MOUNTING PLATE
23	YOKE CAP SCREW
24	DRIVE SLEEVE
25	OPERATOR
26	GLAND PACKING

# PSG

Features	Benefits
The sealing surfaces are coated with chrome-carbide hardcoating to RC 70 hardness, then diamond lapped for a precision fit	The exceptional hardness and temperature ratings to 1800°F make our valves extremely resistant to attack of abrasives and fluids, particularly steam and flashing water.
Designed for ease of maintenance	The only requirement is for the disc to be flat against the seat. This is easily accomplished as there are no precise angles to maintain. Pressure seal bonnet has been designed to facilitate easy removal when necessary.
Protected seats	In the full open position, the flow through "conduit" is positioned precisely between the seats, eliminating turbulence and flow impingements on the seats. There is no gap between our conduit and the valve seat. Small gaps in our competitors' valves cause extreme turbulence and in some cases cavitation.
Self-cleaning	Frequent valve usage polishes the surface for less torque and improved sealing. The high spring load insures contact throughout the stroke of the valve and prevents particulates migrating between the disc and seat also helps assist in the honing action.
Various flow control options, including a v-port orifice	This is ideal for warm-up and some bypass requirements
Stem extensions	Because of the low break away and running torque, various stem extensions are available so that handwheels and actuators can be located remote from the valve.
Tight shut-off	As a standard, ValvTechnologies meets zero leakage requirements on low pressure air and high pressure water
High spring load	ValvTechnologies' very high spring load not only assures good contact between the gate and seat, but at all positions from open to close. This allows zero leakage on hydrogen on vacuum.
Parallel discs	Unlike conventional designs where the discs are only parallel in the closed position, the ValvTechnologies parallel slide valve is designed to maintain its parallel discs from both the fully-open to the fully-closed position.

All content and data are subject to change without notice. Consult factory to verify information.

## Corporate Offices and Manufacturing

Headquarters  
 ValvTechnologies, Inc.  
 5904 Bingle Road  
 Houston, Texas 77092 U.S.A.  
 Telephone +1 713 860 0400  
 Fax +1 713 860 0499  
 sales@valv.com

Master distributors in:

- The Americas
- Europe
- Africa
- Middle East
- India
- Australasia
- China

To locate a master distributor  
 or satellite office near you,  
 visit us online at:  
[www.valv.com](http://www.valv.com)