

Fire Test Report

ANSI/API Standard 607, 5th Edition, June 2005

ISO 10497-5:2004

Performed for

ValvTechnologies Inc.

www.valv.com



8 inch Class 900 H-Series
Metal Seated Ball Valve

Product Code: H7C2-JJ-XX-B080-003-P02

Project Number: 213051

Test Date: March 28, 2013



Performed by

YARMOUTH RESEARCH AND TECHNOLOGY, LLC

434 Walnut Hill Road
North Yarmouth, ME 04097 USA
(207) 829-5359

info@yarmouthresearch.com

www.yarmouthresearch.com

Yarmouth Research and Technology, LLC

Customer: Valvtechnologies

Date: 3/28/2013

Specification: ANSI/API Standard 607, 5th Edition, June 2005

ISO 10497-5:2004

Product Description: 8 inch Class 900 H-Series Metal Seated Ball Valve

Product Code: H7C2-JJ-XX-B080-003-P02

Project Number: PN213051

Yarmouth Engineer: Matthew J. Wasielewski, P.E.

Equipment Confirmed to be in Calibration to NIST Standards: Yes

Burn and Cool Down Test

Burn Start Time:	10:02:00	
Average Pressure During Burn:	1688	psig
Seat Leak Rate During Burn:	0.0	ml/min
Allowable Seat Leak Rate:	3200	ml/min
External Leak Rate During Burn/Cool Down:	0.0	ml/min
Allowable External Leak Rate:	800	ml/min
Amount of Time of Avg. Cal. Blocks > 650 deg. C:	23.8	minutes
Were Test Conditions Within Compliance?	Yes	
Were the Valve Leakages Below the Allowables?	Yes	

Operational Test

Did Valve Unseat and Open Fully?:	Yes	
Average Pressure During Test:	1669	psig
External Leak Rate After Operating:	0.0	ml/min
Allowable External Leak Rate:	200	ml/min
Was the Leakage Below the Allowable?	Yes	

Does Valve Pass or Fail the Test Standard?	PASS
---	-------------

Witnesses

Matthew J. Wasielewski



YARMOUTH RESEARCH AND TECHNOLOGY

Fire Test Information Sheet

Valve Manufacturer's Name:	ValvTechnologies, Inc.
Valve Manufacturer's Address:	5904 Bingle Road Houston, Tx 77092
Did valve meet all required hydrostatic, leakage and other production pressure tests?	Yes
Valve Product Code:	H7C2-JJ-XX-B080-003-P02
Valve Description	Size: 8" Pressure Rating: 900# Pressure Rating at 100F: 900# Type: H-Series Metal Seated BV Weight: 2385 lbs. Reduced or Full Bore: Full port Body/Bonnet Material: A105 Trim Material: SA-29 Gr. 4130 Seat Material: SA-29 Gr. 4130 Stem / Body Seal Material: SA-29 Gr. 4130 / O-rings (EDR) + Graphite Body Bolting / Body Nut Material: A193 Gr. B7 / A194 Gr. 2H Is valve considered "Soft-Seated"? No
Valve Markings	NA Nameplate Information: Casting Markings:
Assembly Drawing Number / Revision / Date of Issue:	TBA 02/26/2013
Assembly Drawing sent to Yarmouth:	Yes
If valve is fitted with gearbox, state gearbox manufacturer, model number and mechanical advantage:	Rotork IW-6R/420
If valve is non-symmetric, state direction of flow for test:	NA
For double-seated valves, state maximum allowable cavity pressure:	NA
Manufacturer's Contact Name /Date:	

FOR PROPOSAL ONLY

PART LIST		
ITEM	DESCRIPTION	QTY.
1	BODY	1
2	END CAP	2
3	BALL	1
4	STEM	1
5	BELLEVILLE SPRING	2
6	SEAT	2
7	BONNET	1
8	GLAND	1
9	GLAND STUD	12
10	GLAND NUT	12
11	BODY STUD	24
12	BODY NUT	24
13	GLAND PACKING	72
14	BODY SEAL	2
15	KEY	2
16	BACK UP RING	2
17	O-RING	2
18	SEAT SEAL SPACER	2
19	TRUNNION	1
20	TRUNNION CAP	1
21	SEAT GASKET	2
22	OPERATOR	1

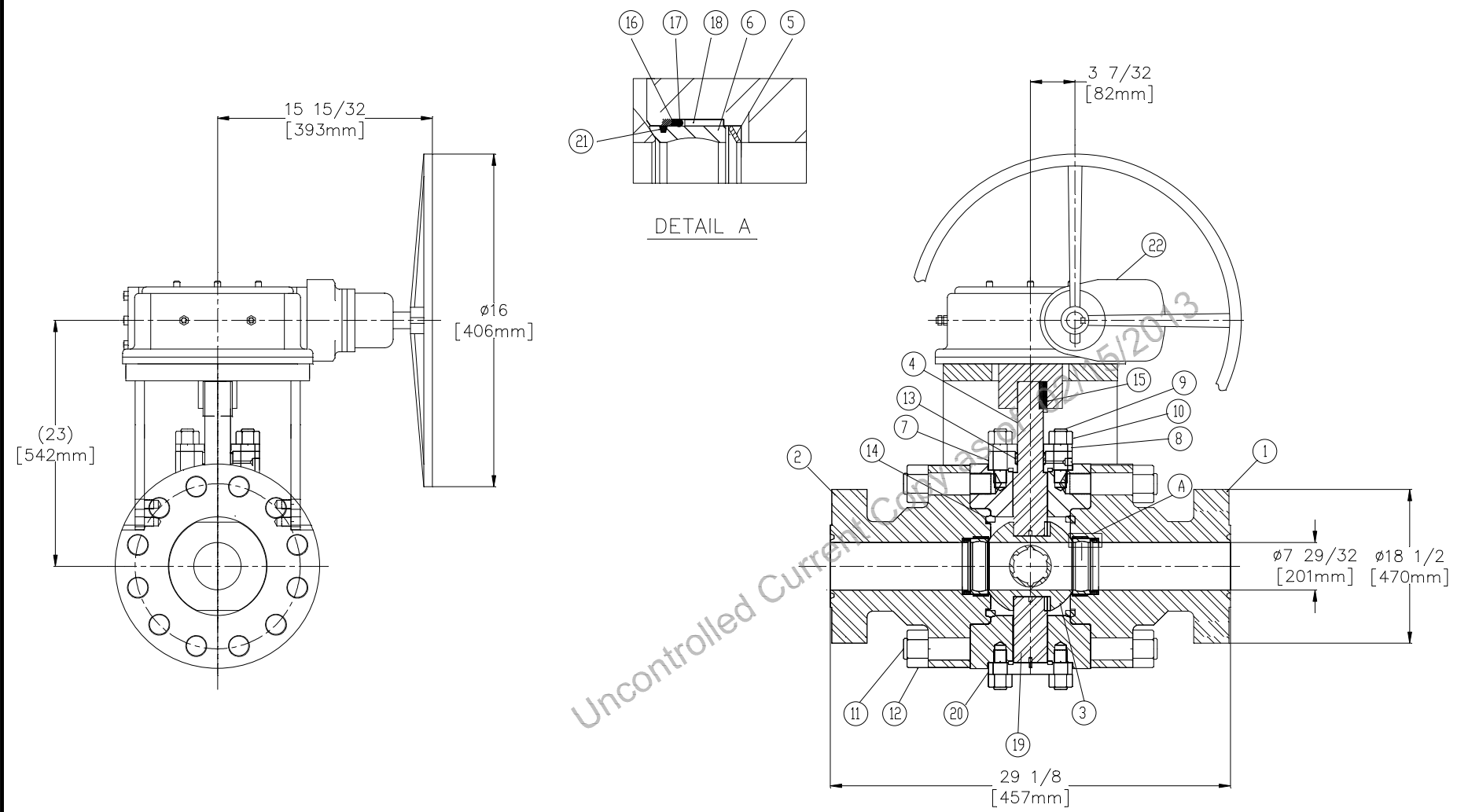

APPROX. ACTUATOR WEIGHT:
185 LBS, [84 KGS]
APPROX. VALVE WEIGHT:
2,200 LBS, [998 KGS]

APPROXIMATE WEIGHTS
TOTAL 2,385lbs [1,082kg]

NOTE: ACTUATOR ORIENTATION IS FOR ILLUSTRATION PURPOSES ONLY AND CAN BE MODIFIED AT TIME OF ORDER ENTRY

CUSTOMER NAME YARMOUTH RESEARCH INSTITUTE	<p>THIRD ANGLE PROJECTION</p> <p>THIS DRAWING AND THE INFORMATION CONTAINED WITHIN IS CONSIDERED TO BE CONFIDENTIAL AND THE SOLE PROPERTY OF VALVTECHNOLOGIES. THE CONTENTS OF THIS DRAWING MAY NOT BE REPRODUCED OR DISCLOSED VERBALLY OR OTHERWISE OUTSIDE THE HOLDERS OFFICE WITHOUT THE WRITTEN APPROVAL OF VALVTECHNOLOGIES.</p>	-	-	-	-	-
CUSTOMER REFERENCE FIRE TEST VALVE		-	-	-	-	-
VALVTECHNOLOGIES REFERENCE -		-	-	-	-	-
PROJECT NAME Nextech 3-Piece Design Fire Certification		-	-	-	-	-

REV	DATE	DESCRIPTION	BY	APR

DIMENSIONS ARE IN INCHES [MILLIMETERS]	
NOT TO SCALE	
DRAWN PN	DATE 02/26/13
APPROVED -	DATE -

5904 BINGLE ROAD, HOUSTON TEXAS 77092, USA
TEL +1 (713) 860-0400 FAX +1 (713) 860-0499

TITLE
H7C2-JJ-XX-B080-003-P02
ansi 900#, WITH BARE STEM
EXECCO IW6R/420

8in 900# Nextech 3-Piece

Temperature verses Time Chart

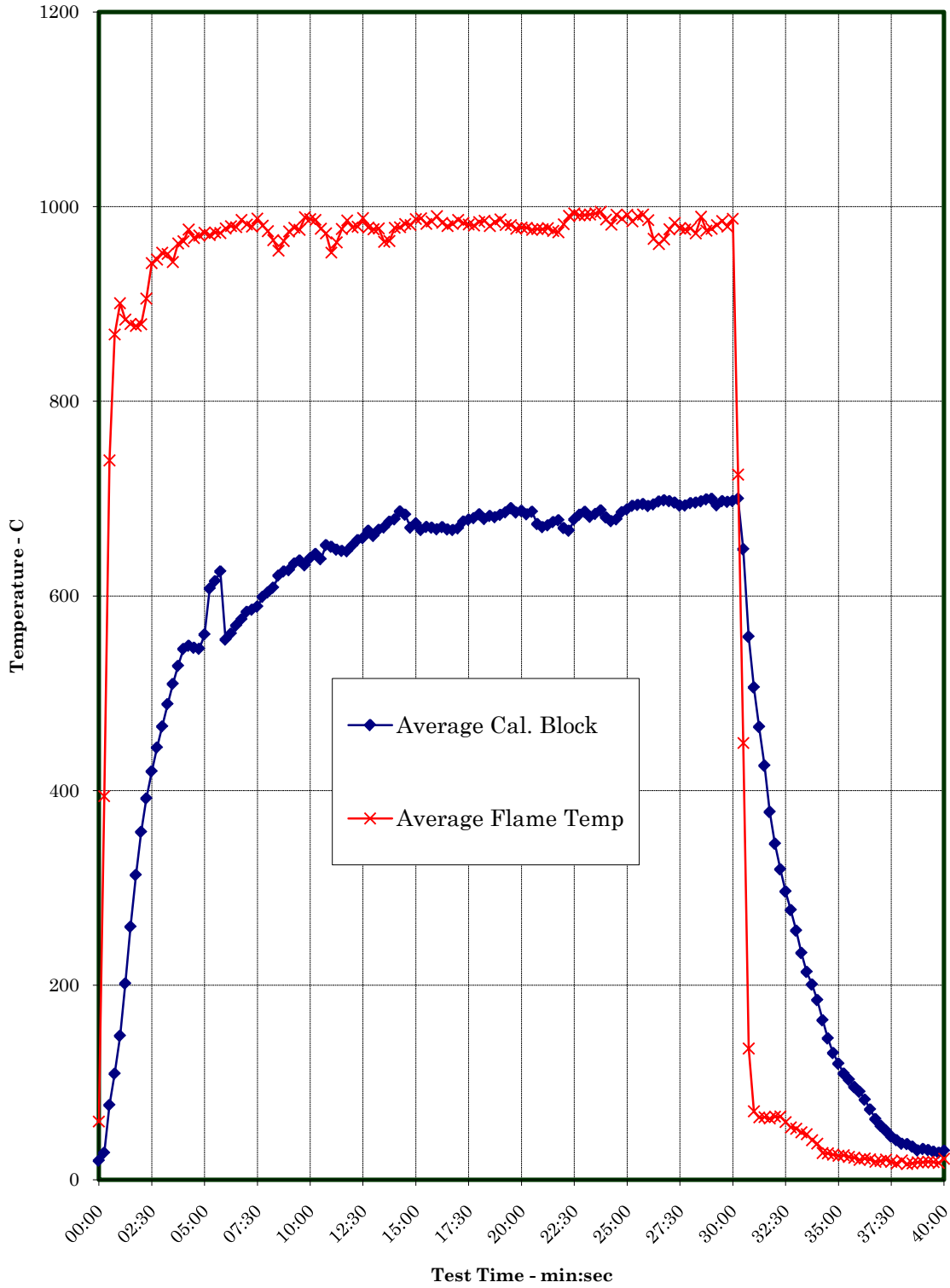

Pressure versus Time Chart

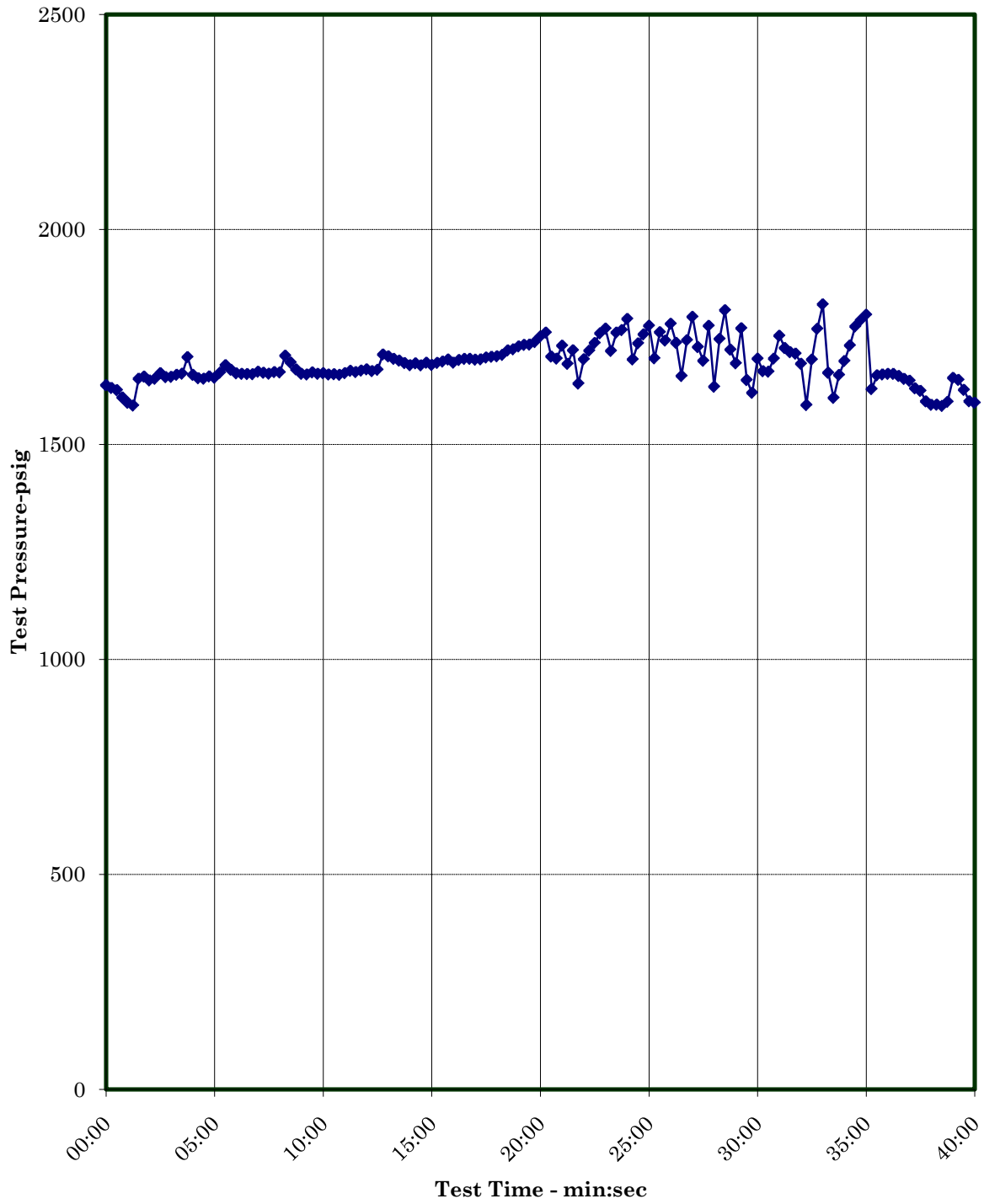



Test Valve Setup Prior to Burn

Yarmouth Research and Technology, LLC



Test Valve During Burn

Yarmouth Research and Technology, LLC

Fire Test Information

Customer: Valvtechnologies

Date: 3/28/2013

Product Code: 8 inch Class 900 H-Series Metal Seated Ball Valve

Project Number: PN213051

Fire Test Raw Data

Time (EST)	Pressure (psig)	Water Volume (mls)	Cal. Block 1 Temp-C	Cal. Block 2 Temp-C	Cal. Block 3 Temp-C	Avg. Cal Block Temp-C	Bonnet Flame Temp-C	Body Flame Temp-C	Average Flame Temp-C
10:02:00	1638	49296	21	21	18	20	57	63	60
10:02:15	1631	49287	29	32	22	28	462	327	394
10:02:30	1626	49289	69	96	66	77	832	647	739
10:02:45	1609	49277	109	114	104	109	918	819	869
10:03:00	1597	49279	167	157	121	148	925	877	901
10:03:15	1590	49299	232	216	157	202	928	839	884
10:03:30	1653	49267	292	277	211	260	930	829	879
10:03:45	1658	49269	342	331	266	313	930	825	878
10:04:00	1649	49255	382	376	314	357	932	827	879
10:04:15	1653	49261	414	409	352	392	939	872	906
10:04:30	1666	49245	441	437	381	420	952	932	942
10:04:45	1656	49259	465	460	407	444	950	941	946
10:05:00	1657	49273	488	481	428	466	976	930	953
10:05:15	1662	49258	513	504	449	489	989	913	951
10:05:30	1664	49251	536	523	469	509	980	906	943
10:05:45	1703	49243	556	542	487	528	996	928	962
10:06:00	1662	49241	573	559	504	545	1004	925	964
10:06:15	1654	49225	588	573	484	549	1007	946	976
10:06:30	1653	49225	604	587	448	547	985	951	968
10:06:45	1658	49224	617	597	423	546	986	955	970
10:07:00	1655	49232	628	608	444	560	996	951	973
10:07:15	1667	49237	639	619	564	607	988	954	971
10:07:30	1684	49222	648	628	568	615	991	956	973
10:07:45	1674	49216	656	637	582	625	988	957	973
10:08:00	1665	49212	665	646	354	555	994	961	978
10:08:15	1664	49216	674	653	356	561	997	963	980
10:08:30	1664	49230	682	661	366	569	1000	958	979
10:08:45	1663	49224	688	668	372	576	1006	967	986
10:09:00	1669	49217	694	674	382	584	1009	954	982
10:09:15	1667	49233	701	680	376	586	1007	952	979
10:09:30	1664	49211	708	684	374	589	1011	965	988
10:09:45	1668	49221	713	689	394	599	1006	956	981
10:10:00	1667	49221	718	694	398	604	1015	934	975

Yarmouth Research and Technology, LLC

Fire Test Data - continued

10:10:15	1706	49189	723	698	429	617	1009	922	966
10:10:30	1690	49201	728	705	434	622	1009	900	955
10:10:45	1675	49214	732	709	432	624	1013	916	965
10:11:00	1664	49217	735	712	446	631	1005	944	974
10:11:15	1663	49205	738	715	450	634	1004	953	978
10:11:30	1667	49193	742	717	431	630	1009	943	976
10:11:45	1664	49202	744	719	448	637	1015	963	989
10:12:00	1666	49187	748	719	458	642	1006	969	987
10:12:15	1663	49211	750	721	438	636	1008	965	986
10:12:30	1663	49207	752	723	478	651	1002	953	977
10:12:45	1662	49206	753	726	467	649	997	948	973
10:13:00	1666	49233	755	729	453	646	1003	902	953
10:13:15	1671	49232	757	732	446	645	1002	925	963
10:13:30	1668	49197	759	733	443	645	996	958	977
10:13:45	1672	49212	760	734	458	651	1010	962	986
10:14:00	1675	49200	761	736	471	656	1016	941	979
10:14:15	1670	49201	765	736	469	657	1021	938	979
10:14:30	1674	49221	768	741	491	666	1021	956	988
10:14:45	1709	49183	770	740	470	660	1023	934	979
10:15:00	1705	49196	772	743	488	667	1008	945	977
10:15:15	1699	49198	772	743	493	670	1012	943	978
10:15:30	1695	49205	773	744	512	676	1005	923	964
10:15:45	1689	49189	772	744	518	678	1003	927	965
10:16:00	1684	49199	773	745	542	686	1008	948	978
10:16:15	1689	49200	774	744	528	682	1017	941	979
10:16:30	1684	49209	777	745	488	670	1010	954	982
10:16:45	1690	49215	778	744	498	674	1017	945	981
10:17:00	1685	49206	778	746	477	667	1016	959	987
10:17:15	1690	49193	779	746	483	670	1012	964	988
10:17:30	1693	49179	782	747	479	669	1014	950	982
10:17:45	1697	49210	783	747	472	668	1018	952	985
10:18:00	1690	49214	784	748	477	670	1018	963	990
10:18:15	1696	49214	786	749	469	668	1017	950	983
10:18:30	1699	49205	787	749	465	667	1010	950	980
10:18:45	1699	49193	788	750	469	669	1002	963	982
10:19:00	1697	49178	788	750	491	676	1005	968	986
10:19:15	1698	49222	789	749	495	678	1011	956	983
10:19:30	1702	49210	789	751	501	680	1007	956	982
10:19:45	1704	49216	788	751	511	683	1004	957	981
10:20:00	1705	49217	789	752	495	679	1003	966	984
10:20:15	1708	49188	789	752	503	682	1002	969	986
10:20:30	1719	49224	790	753	498	680	996	964	980
10:20:45	1721	49193	791	753	504	683	1007	962	984

Yarmouth Research and Technology, LLC

Fire Test Data - continued

						#DIV/0!				
10:21:00	1728	49213	792	753	504	683	1013	961	987	
10:21:15	1731	49214	793	753	511	686	997	965	981	
10:21:30	1732	49204	793	753	524	690	997	966	981	
10:21:45	1738	49217	793	753	511	686	997	957	977	
10:22:00	1751	49228	793	754	514	687	1003	954	979	
10:22:15	1760	49205	794	755	502	684	1001	956	978	
10:22:30	1704	49204	794	756	509	686	996	957	976	
10:22:45	1699	49203	794	757	471	674	991	963	977	
10:23:00	1730	49225	794	757	461	671	997	957	977	
10:23:15	1687	49220	794	757	466	672	998	958	978	
10:23:30	1719	49201	795	758	474	676	992	958	975	
10:23:45	1641	49221	794	759	479	678	978	969	974	
10:24:00	1698	49204	793	758	457	670	993	971	982	
10:24:15	1718	49206	795	758	448	667	1007	974	991	
10:24:30	1736	49213	797	759	479	678	1014	972	993	
10:24:45	1758	49210	799	758	493	683	1013	969	991	
10:25:00	1769	49217	801	760	498	686	1013	970	991	
10:25:15	1717	49190	802	761	481	681	1007	977	992	
10:25:30	1760	49181	802	762	489	684	1009	977	993	
10:25:45	1766	49167	802	763	498	688	1012	978	995	
10:26:00	1792	49145	803	763	476	681	1006	967	987	
10:26:15	1698	49176	803	764	463	677	987	976	981	
10:26:30	1735	49172	802	763	471	679	1003	981	992	
10:26:45	1756	49172	802	765	491	686	996	979	988	
10:27:00	1776	49190	801	764	501	689	1002	982	992	
10:27:15	1700	49179	802	766	510	692	998	971	985	
10:27:30	1761	49175	803	766	511	693	1003	977	990	
10:27:45	1741	49162	803	768	512	694	999	985	992	
10:28:00	1780	49160	802	768	507	692	990	982	986	
10:28:15	1736	49120	802	768	512	694	975	959	967	
10:28:30	1659	49202	801	769	521	697	997	926	962	
10:28:45	1742	49200	801	769	524	698	989	944	966	
10:29:00	1797	49149	801	771	520	697	984	969	977	
10:29:15	1726	49130	801	772	514	696	981	986	983	
10:29:30	1694	49154	800	772	506	693	976	979	978	
10:29:45	1776	49173	799	772	507	693	974	978	976	
10:30:00	1634	49134	799	774	513	695	969	987	978	
10:30:15	1745	49158	799	773	515	696	993	952	973	
10:30:30	1812	49137	801	774	516	697	1004	976	990	
10:30:45	1720	49140	803	774	520	699	1001	949	975	
10:31:00	1688	49163	804	774	521	700	1003	952	977	
10:31:15	1770	49155	805	777	497	693	994	968	981	
10:31:30	1650	49136	806	777	509	697	1004	966	985	

Yarmouth Research and Technology, LLC

Fire Test Data - continued

10:31:45	1620	49151	806	778	506	696	994	965	979
10:32:00	1699	49143	806	779	507	697	998	977	988
10:32:15	1670	49145	793	776	531	700	719	730	725
10:32:30	1669	49144	667	747	529	648	433	465	449
10:32:45	1699	49196	479	702	493	558	88	182	135
10:33:00	1753	49164	386	637	495	506	77	64	71
10:33:15	1724	49174	334	578	484	465	65	63	64
10:33:30	1714	49164	301	488	488	426	59	70	64
10:33:45	1711	49165	273	379	482	378	62	64	63
10:34:00	1687	49157	247	325	464	345	66	64	65
10:34:15	1592	49141	223	292	442	319	65	66	65
10:34:30	1697	49134	201	267	421	296	63	56	59
10:34:45	1769	49124	186	235	411	277	64	43	54
10:35:00	1826	49101	173	197	398	256	64	41	53
10:35:15	1667	49148	154	163	382	233	59	38	49
10:35:30	1608	49161	141	133	368	214	56	38	47
10:35:45	1661	49124	127	112	364	201	47	34	41
10:36:00	1694	49146	111	95	348	185	42	33	37
10:36:15	1730	49176	88	76	328	164	31	24	28
10:36:30	1774	49125	70	59	307	145	28	27	27
10:36:45	1789	49164	59	50	282	130	27	25	26
10:37:00	1801	49147	49	42	267	119	29	21	25
10:37:15	1629	49138	43	38	247	109	27	23	25
10:37:30	1661	49144	39	32	237	103	26	21	24
10:37:45	1663	49155	36	30	221	96	24	22	23
10:38:00	1664	49130	34	29	209	91	20	21	21
10:38:15	1664	49164	32	27	188	82	24	20	22
10:38:30	1659	49143	30	25	162	72	23	19	21
10:38:45	1652	49138	29	24	134	63	21	17	19
10:39:00	1648	49105	29	24	114	56	20	19	19
10:39:15	1631	49087	29	23	100	51	22	20	21
10:39:30	1624	49101	27	19	88	45	20	17	19
10:39:45	1600	49133	27	22	74	41	17	17	17
10:40:00	1592	49136	28	21	62	37	20	20	20
10:40:15	1592	49117	28	23	60	37	17	16	16
10:40:30	1590	49132	28	22	53	34	17	17	17
10:40:45	1599	49113	25	18	48	30	19	17	18
10:41:00	1655	49097	27	19	49	32	22	14	18
10:41:15	1650	49081	24	21	47	31	19	18	19
10:41:30	1627	49078	25	21	41	29	18	18	18
10:41:45	1600	49101	26	20	38	28	18	17	18
10:42:00	1597	49111	24	21	45	30	19	24	22

Yarmouth Research and Technology, LLC

Leakage Summary for Burn and Cool Down Periods

All pressure transducers and thermocouples are in calibration per YRT's QA program.

Seat leakages were collected manually. External leakage was collected electronically.

Total Through Seat Leakage Collected Over 30 Minute Duration:	0.0	mls
Average Leak Rate Over 30 Minute Duration:	0.0	ml/min
Allowable Leak Rate:	3200	ml/min

Total Through Seat Leakage Collected Over 10 Minute Cool Down:	0	mls
--	---	-----

Total Water Volume Lost Over 40 Minute Burn and Cool Down:	185	mls
Water Collected in System Relief Valve:	185	mls
Calculated External Leakage During 40 Minute Duration:	0.0	mls
Average Leak Rate Over 40 Minute Duration:	0.0	ml/min
Allowable Leak Rate:	800	ml/min

Were the Valve Leakages Below the Allowables?	Yes
--	------------

Yarmouth Research and Technology, LLC

Summary of Test Parameters During Burn and Cool Down Periods

Amount of Time Pressure Dropped Below 50%:	0.0	minutes
Maximum Allowable Low Pressure Time:	2.0	minutes
Maximum Pressure During Burn/Cool Down:	1825.5	psig
Average Pressure During Burn/Cool Down:	1687.7	psig
Minimum Pressure During Burn/Cool Down:	1589.6	psig
Amount of Time of Avg. Cal Block > 650 deg.C:	23.8	minutes
Minimum Allowable Time at Temperature:	15.0	minutes
Maximum Avg Cal Block Temperature:	14	deg. C
Average Cal Block Temperature:	12	deg. C
Lowest Avg Cal. Block Temperature:	9	deg. C
Maximum Body Flame Temperature During Burn:	987	deg. C
Average Body Flame Temperature During Burn:	935	deg. C
Maximum Bonnet Flame Temperature During Burn:	1023	deg. C
Average Bonnet Flame Temperature During Burn:	984	deg. C
Average of Both Flame Temperatures During Burn:	960	deg. C

Note

Were Test Conditions Within Compliance?	Yes
---	-----

Yarmouth Research and Technology, LLC

Post-Burn Seat Test Information

Customer: Valvtechnologies

Date: 3/28/2013

Product Code: 8 inch Class 900 H-Series Metal Seated Ball Valve

Project Number: PN213051

This test not required for Pressure Class 900

Yarmouth Research and Technology, LLC

Operational Test Information

Customer: Valvtechnologies

Date: 3/28/2013

Product Code: 8 inch Class 900 H-Series Metal Seated Ball Valve

Project Number: PN213051

Test Data

Time	Pressure (psig)	Cal Block Temp - C
11:18:42	1680	20
11:18:57	1677	20
11:19:12	1680	20
11:19:27	1677	19
11:19:42	1674	20
11:19:57	1676	20
11:20:12	1671	20
11:20:27	1667	20
11:20:42	1672	20
11:20:57	1668	20
11:21:12	1669	21
11:21:42	1666	20
11:21:57	1667	20
11:22:12	1664	20
11:22:27	1658	21
11:22:42	1664	20
11:22:57	1661	21
11:23:12	1667	20
11:23:27	1661	20
11:23:42	1664	20

Leakages were collected manually.

Total External Leakage Collected Over 5 Minute Duration:	0.0	mls
Average Leak Rate Over 5 Minute Duration:	0.0	ml/min
Allowable Leak Rate:	200	ml/min

Was the Valve Leakage Below the Allowable?	Yes
--	-----