

## FORGED HIGH-PRESSURE VALVES

Technical Data	
Sizes	3/4 - 4"
Pressure Classes	ASME / ANSI Class 900 - 3100
Temperature Range	up 1100°F (-29 up 593°C)
Materials of Construction	Carbon steel (A105) Alloy steel (F22, F91)
In Compliance	ASME B16.34 PED
End Connections	Socketweld, buttweld Others available upon request
Warranty	Four year zero-leakage guarantee*

Valve Nominal Size	Pipe ID	Transition Angle	Bore	Cv Based on Pipe ID	Max Cv of Valve
3/4"	Sch 80 0.742	5°	0.63	44	44
1"	Sch 160 0.815	10°	0.63	44	44
1-1/4"	Sch XXS 0.896	10°	0.63	31	44
1-1/2"	Sch XXS 1.100	15°	0.63	22	44
2"	Sch XXS 1.503	10°	1.06	80	136
2"	Sch XXS 1.503	0°	1.5	19	44
2-1/2"	Sch XXS 1.771	15°	1.06	58	136
3"	Sch XXS 2.300	20°	1.06	60	143
3"	Sch XXS 2.300	15°	1.5	162	284
4"	Sch XXS 3.152	30°	1.5	91	284

Since the pipe I.D. and corresponding transition from valve I.D. to pipe I.D. has a critical impact on the Cv of the valve, we have devised the above table. This table gives the Cv based on industry standard pipe and also the maximum Cv of the valve only. For Cv with other pipe I.D. or bore size, consult factory. Cv values are approximate, contact factory for exact Cv values.

## PRESSURE / TEMPERATURE RATINGS

### A182-F22 Class 3 (2 1/4 Cr - 1 mo.)\*\*\* (Temperature F°)

ANSI Rating	-20 to 100	200	300	400	500	600	650	700	750	800	850	900	950	1000	1050	1100
900	2250	2250	2185	2115	1995	1815	1765	1705	1595	1525	1460	1350	1160	800	525	330
1500	3750	3750	3640	3530	3325	3025	2940	2840	2660	2540	2435	2245	1930	1335	875	550
2500	6250	6250	6070	5880	5540	5040	4905	4730	4430	4230	4060	3745	3220	2230	1455	915
3100	7750	7750	7527	7292	6868	6249	6081	5866	5492	5244	5034	4644	3993	2764	1806	1134

### A105 (Carbon Steel)\*\* (Temperature F°)

ANSI Rating	-20 to 100	200	300	400	500	600	650	700	750	800
900	2220	2035	1965	1900	1810	1705	1650	1590	1520	1235
1500	3705	3395	3270	3170	3015	2840	2745	2665	2535	2055
2500	6170	5655	5450	5280	5025	4730	4575	4425	4230	3430
3100	7652	7014	6760	6548	6230	5866	5675	5486	5244	4252

### A182-F91 Type 1 (9Cr - 1 Mo.) (Temperature F°)

ANSI Rating	-20 to 100	200	300	400	500	600	650	700	750	800	850	900	950	1000	1050	1100
900	2250	2250	2185	2115	1995	1815	1765	1705	1595	1525	1460	1350	1160	1090	1080	895
1500	3750	3750	3640	3530	3325	3025	2940	2840	2660	2540	2435	2245	1930	1820	1800	1490
2500	6250	6250	6070	5880	5540	5040	4905	4730	4430	4230	4060	3745	3220	3030	3000	2485
3100	7750	7750	7527	7292	6868	6249	6081	5866	5492	5244	5034	4644	3993	3756	3720	3082

Working pressures are in accordance with ASME/ANSI B16.34-2020. \*Power applications.

Pressure-temperature ratings are in accordance with ASME/ANSI B16.34-2020.

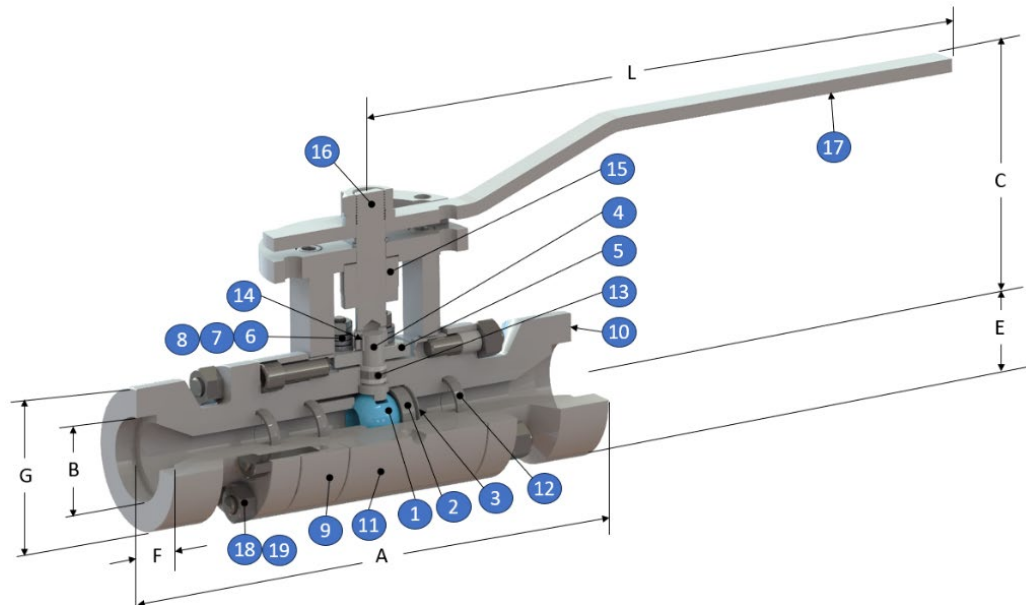

## FEATURES

**Integral metal seat.** Proprietary HVOF RiTech® coating technology ensures the integral seat in ValvTechnologies' valves is resistant to the attack of abrasive magnetite and ferrous oxides.

**Body seal ring.** Field-proven seal ring technology to ensure sealing under all operating conditions up to 1500°F.

**Patented coating process.** With surfaces hardness of 4" Sch XXS 3.152 30° 1.5 91 28468 - 72 Rc, uninterrupted operation and superior wear resistance is assured even in the most severe conditions.

**Live-loaded gland area.** Featuring a four stud, live-loaded assembly designed for heavy industrial applications. Ensures zero emissions from stem packing in the most severe applications.

**True blow-out proof stem.** Design utilizes a one-piece, hard faced, blow out proof stem that is inserted through the inside of the body cavity eliminating the possibility of blow-out through the gland area.

**Absolute zero-leakage.** Every valve tested per ANSI procedures; however, we toughen the standard and define zero leakage as no detectable leakage of gas or a liquid for a period of three minutes or greater. The ValvTechnologies' standard is zero drops and zero bubbles. guaranteed.

V1-R Butt Weld, Class 900-3100, Full port

NPS	A	C	D	E	G	L	Weight lbs.
	3100	2500	2500	2500	2500	2500	2500
3/4"	11.5	4.50	1.94	1.19	1.05	7.1	22
1"	11.5	5.88	2.75	1.75	1.32	15	22
1-1/4"	14.5	5.88	2.75	1.75	1.66	15	45
1-1/2"	14.5	5.88	2.75	1.75	1.90	15	45
2"	18	6.68	3.81	2.13	2.38	15	130

V1-R Socket Weld, Class 900-3100, Full port

NPS	A	B	C	E	F	G	L	Weight lbs.
	3100	2500	3100	3100	2500	3100	3100	3100
3/4"	11.5	1.07	5.91	1.63	0.50	3.25	15	30.3
1"	11.5	1.34	5.91	1.63	0.50	3.25	15	23
1-1/4"	11.5	1.69	5.91	1.63	0.50	3.25	15	23
1-1/2"	14.5	1.93	5.88	2.00	0.50	4.00	15	44
2"	18	2.41	6.68	2.28	0.63	4.56	15	129.6

Item	Description	Material		
		F22 (2 1/4 Cr-1 Mo.) Alloy Steel	A105 CARBON Steel Body Trim	F91 (8.75 -0.95Cr-0.22V) Alloy Steel
1*	Ball	A182 Gr. F6a/HVOF RiTech® 31	A182 Gr. F6a/HVOF RiTech® 31	SB-637 N07718
2*	Upstream seat	SA-182 Gr. F22 CI 3/H.F.	SA-182 Gr. F22 CI 3/H.F.	SA-182 Gr. F22 CI 3/H.F.
3*	Belleville® spring	SB-637 N07718	SB-637 N07718	SB-637 N07718
4	Stem	A638 Gr. 660/H.F	A638 Gr. 660/H.F	A638 Gr. 660 /H.F
5	Gland	SA-182 Gr. F316/H.F	SA-182 Gr. F316/H.F	SA-182 Gr. F316/H.F
6	Gland load spring	UNS N07718	UNS N07718	UNS N07718
7	Gland nut	SA-194 Gr.8M	SA-194 Gr. 8M	SA-194 Gr. 8M
8	Gland stud	SA-193 Gr. B8M	SA-193 Gr. B8M	SA-193 Gr. B8M
9*	End cap/integral seat	SA-182 F22/HVOF RiTech® 31	SA-105/HVOF RiTech® 31	SA-182 F91/HVOF RiTech® 31
10	End Cap	SA-182 F22	SA-105	SA-182 F91
11	Body	SA-182 F22	SA-105	SA-182 F91
12*	Body seal	SB-637 N07718	SA-564 Type630 H1156D/PT24	SB-637 N07718/PT24
13*	Gland packing	ANSI 316/Grafoil®	ANSI 316/Grafoil®	ANSI 316/Grafoil®
14	Key	SA-29 Gr. 1018	SA-29 Gr. 1018	SA-29 Gr. 1018
15	Thrust bearing	A29-1020/H.F.	A29-1020/H.F.	A29-1020/H.F.
16	Drive sleeve	SA-29 Gr. 4130	SA-29 Gr. 4130	SA-29 Gr. 4130
17	Handle	Steel	Steel	Steel
18*	Body stud	SB-637 N07718	SA-193 Gr. B7	SB-637 N07718
19*	Body nut	SB-637 N07718	SA-194 Gr. 2H	SB-637 N07718
20	Stop plate	SA-216 Grade WCB	SA-216 Grade WCB	SA-216 Grade WCB

\*Recommend spare parts